

DAM BUSTER®

Achieve Compliance & Conformance with Dam Buster® Products

NOTE: All Dam Buster® products are protected by various Australian & International Patents.



This document is to be read in conjunction with the Dam Buster publications titled 'Evidence of Suitability', 'Installation Manual' & 'Quick Design Guide'. Together, these documents set out the design requirements, as well as usage conditions and limitations for the use of Dam Buster's products.

PRODUCT TECHNICAL STATEMENT

Version 6.92 (05 April 2026)

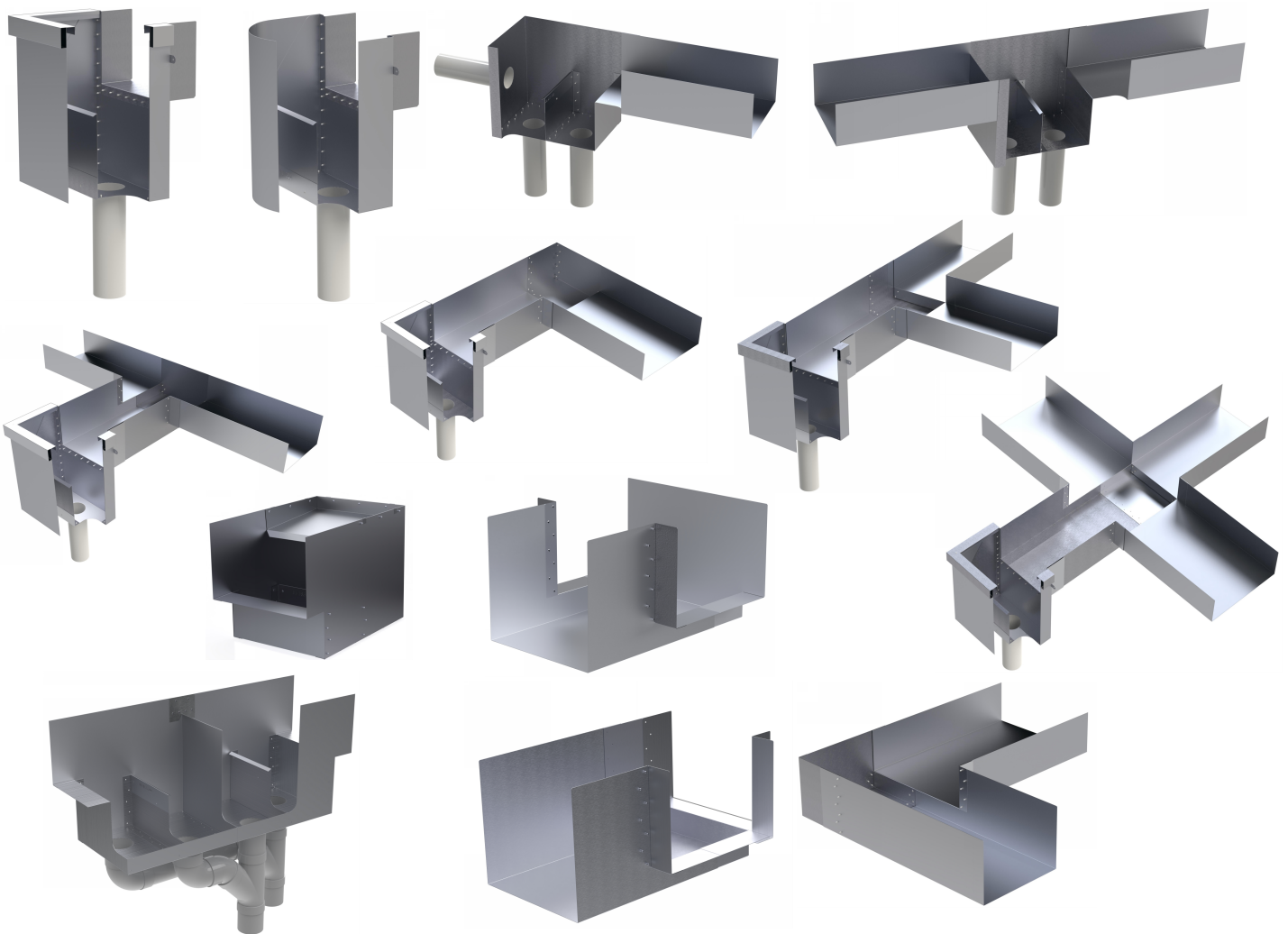

CERTIFIED PRODUCT (DAM BUSTER RAINHEAD)

For testing the Overflow Performance of Dam Buster rectangular rainheads.



**GOOD
DESIGN
AWARD®
WINNER 2018**

**PRODUCT DESIGN
HARDWARE AND BUILDING
DAM BUSTER
RAINHEAD**

"The Architectural Choice"

www.dambuster.com.au

Dam Buster Roof Drainage System - Product Range

Overflow devices (1 of 2)

Protected by various Australian and International Patents

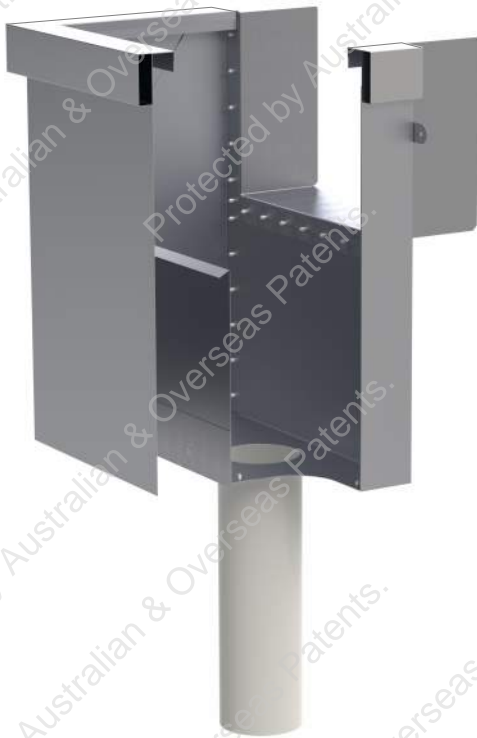

Dam Buster Rainhead



Dam Buster Curved Fronted Rainhead

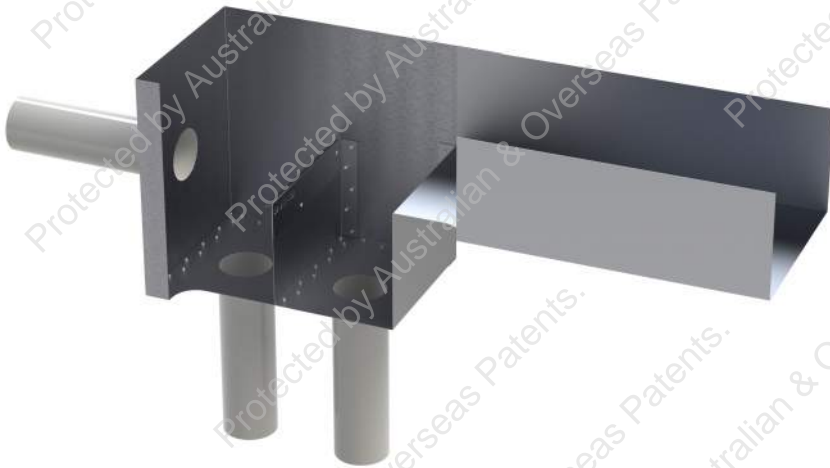

Dam Buster Sump

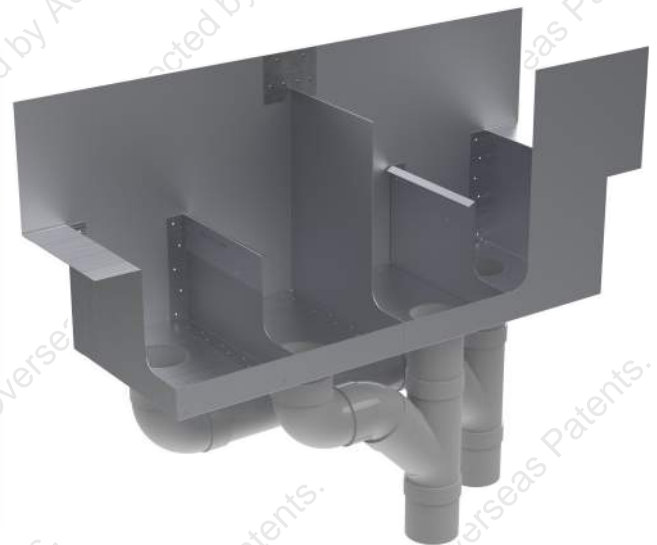

Dam Buster Back-to-Back Sump



Dam Buster Continuous Sump

Dam Buster Roof Drainage System - Product Range (cont)

Overflow devices (2 of 2)

Protected by various Australian and International Patents

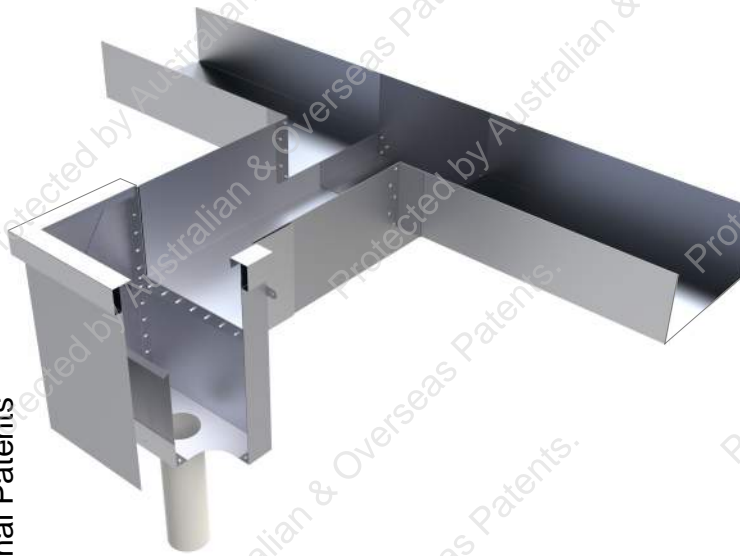

Dam Buster T Side Outlet & Rainhead

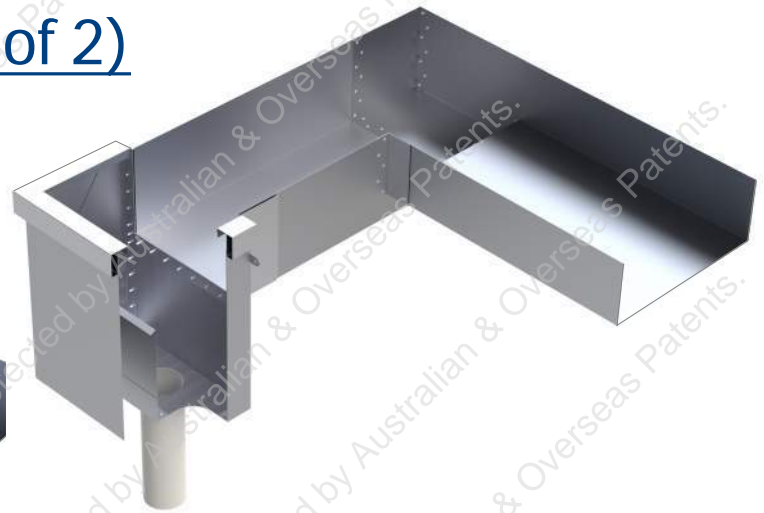

Dam Buster END Side Outlet & Rainhead (LH & RH forms available)



Dam Buster CORNER Side Outlet & Rainhead (LH & RH forms available)

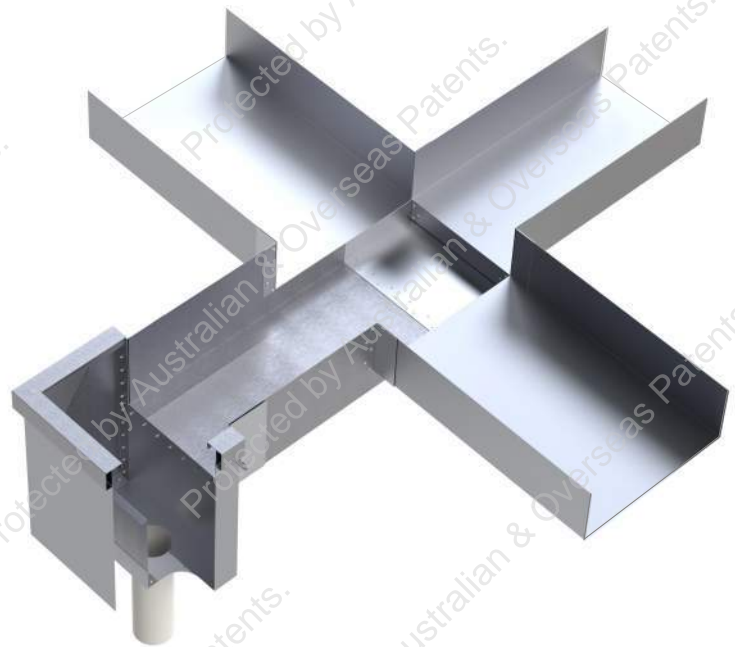

Dam Buster CRUCIFORM Side Outlet & Rainhead



Dam Buster END Side Outlet & Sump (LH & RH forms available)

NOTE

The following Side Outlet & Sump combinations are also possible

Dam Buster T Side Outlet & Sump

Dam Buster Corner Side Outlet & Sump

Dam Buster Cruciform Side Outlet & Sump

Dam Buster Roof Drainage System - Product Range (cont)

Upstream devices

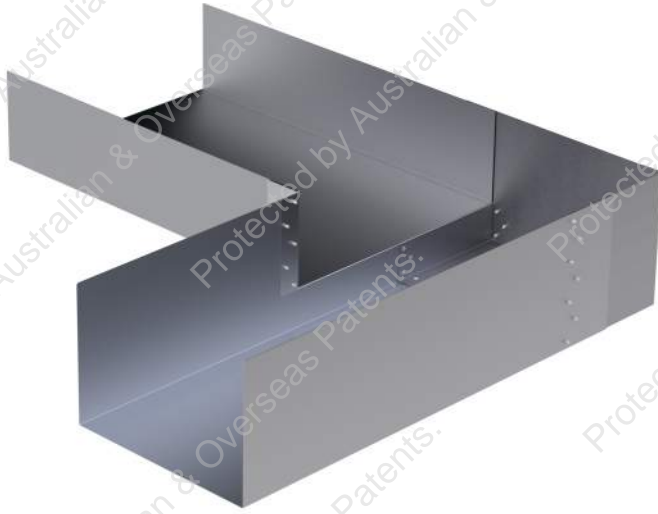

Dam Buster Elbow

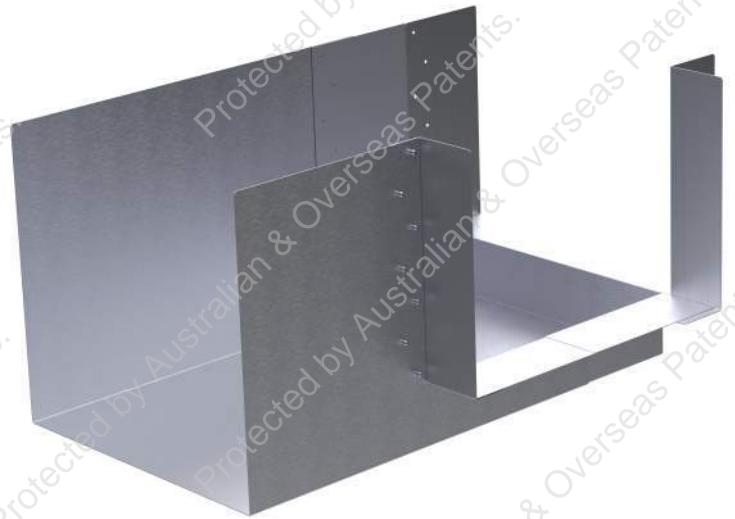

Dam Buster Corner Junction

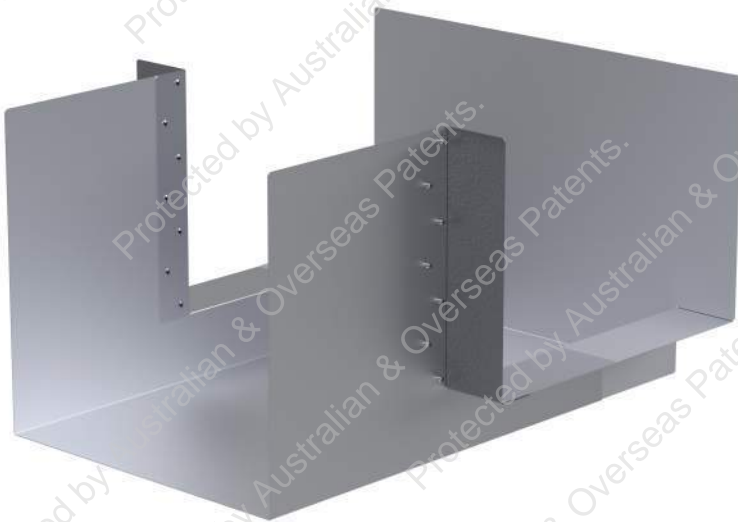

Dam Buster T Junction



INDEX

Item	Description	Page(s)
1.	Product descriptions	6
2.	Application and intended use	6
3.	Compliance with the National Construction Code	6
4.	Limitations of use	7
5.	Conditions of use	7
6.	Instructions for Design	
	A – Box gutter(s) to a Dam Buster overflow device	8 – 12
	B - Dam Buster Elbow	13
	C - Dam Buster Junctions	14
7.	Instructions for Installation	15
8.	Risk Management (Design) & Maintenance of Box Gutter Systems	15
9.	Intellectual Property and Know-How	16
10.	Support	16
11.	Appendices	17
	A - Dam Buster Product Names	18
	Dam Buster Rainhead Types	19
	Flashing kits for wall flashings	20
	B - Design Example – Dam Buster Rainhead	21 – 22
	C - Dam Buster Standard drawing details	23 – 52
	D - Dam Buster Product Data Sheets	53 – 69
	E – Risk Management & Maintenance of Box Gutter Systems	70 – 74
	F - Dam Buster Box Gutter Design Charts	75 – 79
	G – Aerial downpipe design chart	80 – 81

NOTE

Where this document refers to any code, guide or manual, this reference should be interpreted as being for the current legal version of the code, guide or manual for the relevant state or territory, unless noted otherwise.



1. PRODUCT DESCRIPTIONS

Dam Buster products are comprised of Zinalume, Colorbond or other approved metal materials suitable for use in domestic and/or commercial roof drainage systems.

Models:

- Box gutter overflow devices
 - Dam Buster **Rainhead**
 - Overflow device comprising a Dam Buster **Side Outlet** and a Dam Buster **Rainhead** or a **Dam Buster Sump**
 - Dam Buster **Sump, Continuous Sump** and **Back-to-Back Sump** ('free flow' sumps)
- Ancillary products
 - Dam Buster **Elbow**
 - Dam Buster **Junctions**

2. APPLICATION AND INTENDED USE

The components which form the Dam Buster Roof Drainage System can be used in both domestic and commercial roof plumbing applications. Dam Buster products should only be specified by building design professionals and plumbers who have a good understanding of the relevant codes, and in particular, AS/NZS 3500.3. Dam Buster products should only be installed by licensed roof plumbers.

3. COMPLIANCE WITH THE NATIONAL CONSTRUCTION CODE

Roof drainage falls under NCC Volumes 1 and 2 (i.e. the BCA), however, in Victoria and Tasmania, roof drainage also falls under NCC Volume 3 (i.e. the PCA) as State additions.

Refer to Dam Buster's **Evidence of Suitability** document for the compliance pathways available for Dam Buster's products. Briefly, these are:

<u>Box Gutters</u>	Deemed-to-Satisfy ('DtS') (designed to AS/NZS3500.3)
<u>Dam Buster Devices</u>	Deemed-to-Satisfy by Expert Judgement *
	OR
	Performance Solution

* DtS by Expert Judgement is the preferred pathway for Dam Buster devices, however, if this is not acceptable to the Regulatory Authority and / or Building Surveyor / Certifier, a Performance Solution can be prepared using Dam Buster's Performance Solution templates.



4. LIMITATIONS OF USE

Dam Buster products are suitable for use within all building classes 1 to 10, regardless of height or size. The following limitations apply to Dam Buster Products:

- Dam Buster products must comply with the **Instructions for Design** in this document.
- Dam Buster products must be installed in accordance with the Dam Buster **Installation Manual**.
- In Victoria and Tasmania, roof plumbing must also comply with the current version of SA HB39 *Installation code for metal roof and wall cladding*.
- In Victoria, roof plumbing must also comply with HB114.
- Dam Buster products must be installed by a building professional or roof plumber with a good understanding of AS/NZS 3500.3, and where applicable, SA HB39 and HB114.

5. CONDITIONS OF USE

The building contractor / plumber must only use Dam Buster products in accordance with this Product Technical Statement and install the products in accordance with Dam Buster's Installation Manual. Additionally, the installing plumber must ensure the type of material used provides adequate corrosion protection for the exposure classification. Further information can be obtained from the following BlueScope publications:

- Technical Bulletin 1A - '*Steel roofing products – selection guide.*'
- Technical Bulletin 35 - '*Australian salt marine classifications.*'

The installing plumber must also ensure compatibility of materials to prevent dissimilar metal corrosion.

More generally, the entire roof drainage installation must comply with all relevant requirements of AS/NZS 3500.3, SA HB39 (as applicable*) and SAA/SNZ HB114 (as applicable*).

* HB39 and HB114 are not applicable in all States and Territories.

6. INSTRUCTIONS FOR DESIGN

A - BOX GUTTER(S) TO A DAM BUSTER OVERFLOW DEVICE

- i. Straight box gutters to Dam Buster Rainhead
- ii. Box gutter(s) to a Dam Buster Side Outlet & Rainhead combination
- iii. Box gutter(s) to a Dam Buster Side Outlet & Sump combination

Design procedure

Follow STEPS 1 to 4 below.

STEP 1 - Determine the design rainfall intensity for the location

Option 1

Australia

Select a 1% AEP (annual exceedance probability) design rainfall intensity for a time of concentration of 5 minutes for the location in accordance with Appendix D of AS/NZS 3500.3.

This value is referred to as 100I₅

New Zealand

Select a 2% AEP design rainfall intensity for a time of concentration of 10 minutes for the location in accordance with Appendix E of AS/NZS 3500.3. This value is referred to as 50I₁₀.

Option 2 (for Australia only)

- a) Determine the longitude and latitude for the site
- b) Determine the 1% AEP design rainfall intensity for a 5 minute duration using the Bureau of Meteorology's IFD (Intensity-Frequency-Duration) website:-
<http://www.bom.gov.au/water/designRainfalls/revise-ifd/>

STEP 2 - Determine the roof catchment area and design flow rate for each box gutter associated with the Dam Buster device

NOTE

Each Dam Buster device and its associated box gutter(s) should generally be designed one at a time for the roof drainage project, although the depths of box gutters will need to be rationalised to match as / where required.

For each box gutter discharging to a Dam Buster Box Gutter Overflow device

- a) Determine the roof catchment area in accordance with section 3.4 Catchment area of AS/NZS 3500.3
- b) Convert the catchment area to a flow rate in litres per second:

$$Q = \frac{CA \times \text{Intensity}}{3600}$$

where

CA = catchment area (m²).

Q = the design flow rate in L/s

Intensity = 100I₅ or 50I₁₀ mm/h per step 1

Notes

1) 1mm water depth over 1m² equates to 1 litre

2) The factor 3600 converts the rainfall intensity from L/hour to L/s

NOTE

Refer to page 6 of the Dam Buster Quick Design Guide for a more detailed explanation for calculating the Catchment Area

6. INSTRUCTIONS FOR DESIGN (cont.)

A - BOX GUTTER(S) TO A DAM BUSTER OVERFLOW DEVICE (cont.)

STEP 3 - Design each box gutter associated with the device

- a) Design each box gutter for 'free flow' in accordance with Appendix H, Figure H.1 of AS/NZS 3500.3 to determine the upstream depth. Note, it is recommended this value be rounded up to the nearest 5mm.
Refer to Appendix F for Dam Buster Box Gutter Design Charts.
- b) Determine the increase in depth of the box gutter over its length, based on its slope (which must be between 1 in 200 to 1 in 40), and round this value up to the nearest 5mm.
- c) Add the result in (b) to (a) to determine the design downstream box gutter depth (note, it is assumed the top of the box gutter is level, and the sides are tapered due to the fall).

NOTES

- 1) Box gutters with design flow rates less than 3L/s must be designed for the minimum design flow rate of 3L/s.
- 2) Where there is more than one box gutter discharging to an overflow device comprising a Dam Buster Side Outlet and a Dam Buster Rainhead, the design flow rate is the sum of the actual design flow rates for each box gutter. For example, for a T Side Outlet, if the design flow rates of the two box gutters are 1.5 L/s and 2.0 L/s, both box gutters are designed for 3L/s, however, the rainhead is designed for $1.5 + 2.0 = 3.5$ L/s (not 6L/s).

STEP 4 - Design the Dam Buster device

Dam Buster Rainhead

Select the rainhead / downpipe combination from **Table 1** below, such that the design flow rate is less than the allowable flow rate.

Overflow device comprising Dam Buster Side Outlet and a Dam Buster Rainhead

No design of the Side Outlet itself is required, provided

- (i) the Dam Buster Rainhead is selected as above and
- (ii) the Side Outlets are used within their allowable ranges i.e.
 - 200 Side Outlet - expansion range is 200mm to 300mm (step= 50mm)
 - 300 Side Outlet - expansion range is 300mm to 450mm (step= 60mm)
 - 400 Side Outlet - expansion range is 400mm to 600mm (step= 70mm)

Overflow device comprising Dam Buster Side Outlet and a Dam Buster Sump

Apart from one exception noted below, no design of the Side Outlet itself is required, provided

- (i) the Dam Buster Sump is selected from **Table 2** below,
- (ii) the Side Outlets are used within their allowable ranges i.e.
 - 200 Side Outlet - expansion range is 200mm to 300mm (step= 50mm)
 - 300 Side Outlet - expansion range is 300mm to 450mm (step= 60mm)
 - 400 Side Outlet - expansion range is 400mm to 600mm (step= 70mm)

EXCEPTION to Design Method

For the 200mm Dam Buster Side Outlet and Sump combination (only), the maximum flow rate is limited 5.0 L/s i.e. it is the lessor of the value in **Table 2** and 5.0 L/s.

6. INSTRUCTIONS FOR DESIGN (cont.)

A - BOX GUTTER(S) TO A DAM BUSTER OVERFLOW DEVICE (cont.)

STEP 4 - Design the Dam Buster device (continued)

Dam Buster Sump

Select the sump / downpipe combination from **Table 2** below, such that the design flow rate is less than the allowable flow rate. Design the aerial overflow pipe. **Refer to Appendix G for a design chart.**

Dam Buster Continuous Sump

The Dam Buster Continuous Sump provides a practicable (and more cost effective) alternative to the AS/NZS 3500.3 Dts Sump / High Capacity Overflow device ('HCO'). This device is designed in the exactly the same way as the Dam Buster Sump. The flow occurs in one direction only, and when this device is located on building grids, one device may be eliminated, as there is no device at the first upstream end.

Dam Buster Back-to-Back Sump

The Dam Buster Back-to-Back Sump is effectively a double Sump, and has double the capacity of the Dam Buster Sump, provided the aerial overflow pipe is designed for the total flow in both sumps. The Back-to-Back Sump provides a very high hydraulic capacity and significantly exceeds the hydraulic capacity of the HCO for a similar sump depth. All Dam Buster Sumps can be fitted with a Sump Deflector Cover (SDC) to prevent nuisance flows entering the overflow chamber.

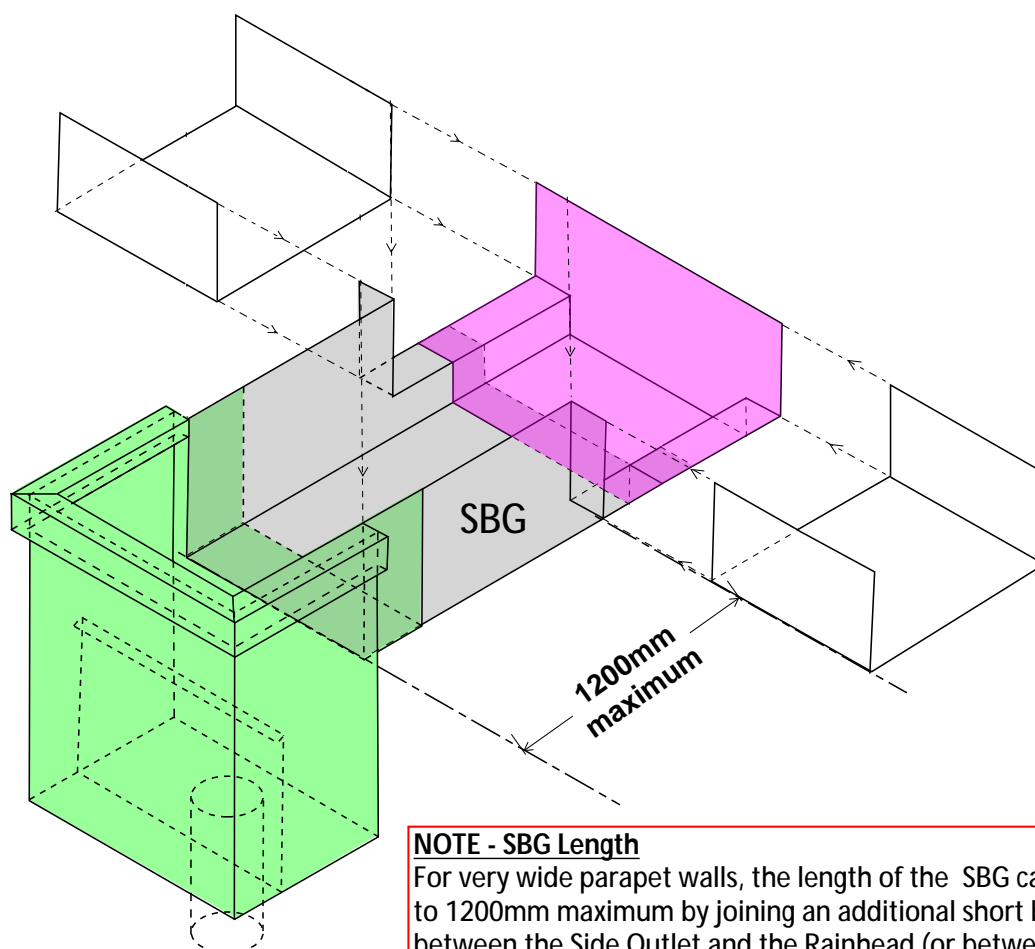

NOTE - SBG Length

For very wide parapet walls, the length of the SBG can be increased to 1200mm maximum by joining an additional short box gutter section between the Side Outlet and the Rainhead (or between the Side Outlet and the Sump). This applies to all Side Outlets.

Maximum Length of Short Outlet Box Gutter ('SBG')

6. INSTRUCTIONS FOR DESIGN (cont.)

A - BOX GUTTER(S) TO A DAM BUSTER OVERFLOW DEVICE (cont.)

TABLE 1 – Dam Buster Rainhead

Downpipe size	Equivalent diameter	Mini RH	Standard Rainhead size ⁽¹⁾				
		MR-200	R-200	R-300	R-400	R-500	R-600
100 x 50	79	3.00	4.00 ⁽²⁾	4.00 ⁽³⁾			
80 diam.	80	3.00	4.00 ⁽²⁾	4.00 ⁽³⁾		Refer note (iv)	
90 diam.	90	4.00	4.70	6.50			
100 x 75	97	4.50	5.00	7.30	8.00		
100 diam.	100	4.50	5.00	7.60	8.80	8.80	
100 x 100	112			8.80	12.0	12.0	
125 diam.	125			9.50	14.2	15.4	15.9
150 x 100	137	Refer note (v)			15.8	16.0	16.0
150 diam.	150				16.0	16.0	16.0
Overflow Capacity of Device (L/s)		>12.0	>16.0	>16.0	>16.0	>16.0	>16.0

NOTES on rainhead capacities.

(1) Curved fronted rainheads CR-www have the same capacity as rectangular rainheads
(2) Capacities determined by testing by the AHSCA Research Foundation
(3) Capacities adopted for R-200 (R-300 not tested yet for these DPs)
(4) 'Stretched' and 'Widened' versions of rainheads are available in the 200 and 300 series. Calculations remain based on Table 1.

Maximum permissible flow rates (litres / sec)

GENERAL NOTES

- (i) Values in black have been determined in accordance with AS/NZS 3500.3
- (ii) Values in red were determined by testing by the AHSCA Research Foundation
- (iii) Values in blue were also determined by testing by the AHSCA Research Foundation.
Note, AS/NZS 3500.3 permits the use of a 100x50 DP, however, no design charts are provided within the standard for this downpipe size, and consequently testing was required.
- (iv) For the R-400, R-500 & R-600, smaller downpipes than noted in the table may be used, provided the maximum permissible capacity is adopted as that for the next lowest rainhead size for which a value in the table is provided, for the same DP size. For example, for a 600 Rainhead, and 90 mm diam. DP, the maximum flow rate is 6.50 L/s.
- (v) These combinations are not possible
- (vi) Rectangular downpipes are considered to be 98% as effective as circular downpipes. Hence the equivalent diameter is based on 0.98 times the area of the rectangular downpipe.
- (vii) The capacities of **STRETCHED** and **WIDENED** rainheads are the same as for the standard versions (i.e. neither of these forms of the rainhead have additional capacity compared to the standard rainhead).
- (viii) **MINI** rainheads apply to the 200 series only. This rainhead has a reduced height only, including a reduced box gutter receiver depth of 150mm. These rainheads are suitable for small areas such as porticos and the flat back version is suitable for eaves gutters. They should not be used with Side Outlets due to the reduced box gutter receiver depth.

6. INSTRUCTIONS FOR DESIGN (cont.)

TABLE 2 – Dam Buster Sump

Normal downpipe size	Overflow Downpipe size	Sump Depth (mm)	Dam Buster Sump width (mm)				
			200	300	400	500	600
90 diam.	90 diam.	75					
“ “	“ “	100	3.00				
“ “	“ “	125		3.30			
“ “	“ “	150	3.60				
90 diam.	100 diam.	75		3.00			
“ “	“ “	100	3.40				
“ “	“ “	125		4.60			
“ “	“ “	150	5.05		5.05		
“ “	“ “	200		5.90	5.90		
100 diam.	100 diam.	75		3.40			
“ “	“ “	125		5.70			
“ “	“ “	150	6.25		6.25	6.25	6.25
“ “	“ “	200		7.30	7.30	7.30	7.30
150 diam.	150 diam.	150			12.2	12.2	12.2
“ “	“ “	200			16.0	16.0	16.0

Maximum permissible flow rates (litres / sec)

Notes

- There is one exception to values in the table above. When used in conjunction with a Side Outlet, the maximum flow rate in the 200 Dam Buster Sump should be limited to 5.0 L/s.
- ☐ denotes sump size not currently available as a standard size, or sump size and DP combination not permitted. Refer to available standard sizes in table below.
- ☐ denotes sump and DP size not recommended, however, the allowable flow rates provided in the same row may be used.
- Aerial overflow downpipes must be designed and installed at adequate grade to achieve the required flow rates. The minimum grades for critical flow rates specified in the design table (for PVC pipes) are provided in the table below for information purposes. These values have been determined from standard calculators based on the Colebrook-White equation. Note, these values apply to straight pipes with no additional bends than the bend below the sump. Where there are additional bends, obtain advice from a hydraulic engineer.

Pipe size	Flow rate	Min grade
90 diam	3.60	1 in 200
“ “ “	4.60	1 in 150
100 diam	5.50	1 in 200
“ “ “	7.30	1 in 120
150 diam	16.0	1 in 200

Refer also Appendix F for an Aerial downpipe design chart.

- IMPORTANT** – AERIAL OVERFLOW PIPES MUST DISCHARGE VISIBLY TO ATMOSPHERE IN ORDER TO ALERT THE BUILDNG MANAGER / BUILDING OWNER / BUILDING OCCUPANT THERE IS A BLOCKAGE IN THE SYSTEM.

Dam Buster sump standard sizes					
Width Depth	200 mm	300 mm	400 mm	500 mm	600 mm
75 mm		300-75			
100 mm	200-100				
125 mm		300-125			
150 mm	200-150		400-150	500-150	600-150
200 mm		300-200	400-200	500-200	600-200

6. INSTRUCTIONS FOR DESIGN (cont.)

B - DAM BUSTER ELBOW

Design procedure

- a) Repeat Steps 1 & 2 on page 8
- b) Determine the total flow rate in the Upstream and Downstream box gutters, and check that this is less than the maximum allowable flow rate in Table 3
- c) Design the Upstream box gutter for the total flow rate noted above in accordance with AS/NZS 3500.3, Appendix H, Figure H.1
- d) Note, there is no need to design the Downstream box gutter due to the increase in depth of the Step-Down in the Elbow.

TABLE 3 – Dam Buster Elbow

Device Size	Maximum Flow Rate (L/s)	Contraction Range for Upstream Gutter	Maximum box gutter depth at Entry (mm)	Drop within Elbow (mm)	Maximum box gutter depth at Exit (mm)
ELB-200	5.0	200	180	50	230
ELB-300	9.5	300 -> 200	215	60	265
ELB-400	16.0	400 -> 300	230	70	300
ELB-500	16.0	500 -> 300	230	70	300
ELB-600	16.0	600 -> 400	230	70	300

NOTES

1. The upstream box gutter is designed (in accordance with figure H.1 of AS/NZS 3500.3) for a flow rate equivalent to the total catchment area of the upstream and downstream box gutters. It is not necessary to design the downstream box gutter.
2. The top of the upstream box gutter, the Elbow, and the downstream box gutter must all be level. Hence the upstream depth of the downstream gutter is equal to the downstream depth of the upstream gutter, plus the drop (and small amount of fall within the Elbow itself).
3. The Elbow is trimmed to match the designed downstream depth of the upstream box gutter. Refer to the Installation Manual.
4. All Elbows are supplied as 'Sliding' Elbows (i.e. supplied in two-piece / adjustable) by default. Sliding Elbows are able to contract for the upstream box gutter width within the specified range (all sizes except 200)
5. 'Fixed' Elbows are also available for special larger volume orders (over 20 units), however fixed Elbows are not adjustable for the upstream box gutter.
6. **ONLY THE UPSTREAM BOX GUTTER MAY BE CONTRACTED. THE DOWNSTREAM BOX GUTTER MAY NOT BE NARROWER THAN THE UPSTREAM BOX GUTTER**

6. INSTRUCTIONS FOR DESIGN (cont.)

C - DAM BUSTER JUNCTIONS

Design procedure

- a) Repeat Steps 1 & 2 on page 8.
- b) Determine the total flow rate in the Upstream and Downstream box gutters, and check that this is less than the maximum allowable flow rate in Table 4
- c) Design the Upstream box gutter having the greater catchment area (the 'critical' upstream box gutter) for the flow rate to this box gutter, plus the flow rate to the downstream box gutter, in accordance with AS/NZS 3500.3, Appendix H, Figure H.1.
- d) The other Upstream box gutter having the lower catchment area (i.e. the 'non-critical' box gutter) is then sized to match the 'critical' box gutter at the entry to the Junction.
- e) Note, there is no need to design the Downstream box gutter due to the increase in depth due to the Step-Down in the Junction

TABLE 4 – Dam Buster Junction

Device Size	Maximum Design Flow Rate (L/s)	Contraction Range for Upstream Gutter	Maximum box gutter depth at Entry (mm)	Drop within Junction (mm)	Maximum box gutter depth at Exit (mm)
TJN-200*	5.0	200	180	50	230
TJN-300**	9.5	300 -> 200	215	60	275
TJN-400***	16.0	400 -> 300	230	70	300
* Also CJN-200-L/R ** Also CJN-300-L/R *** Also CJN-400-L/R					

NOTES

1. The maximum box gutter depth at Entry to the device is the maximum allowable downstream depth of the 'critical upstream box gutter' (refer note 3).
2. The Junction is trimmed to match the design downstream depth of the 'critical upstream box gutter'. Refer to the Installation Manual.
3. The upstream box gutter with the larger catchment area (the 'critical upstream box gutter') only is designed, and the opposite upstream box gutter ('non-critical box gutter') is sized to match the 'critical box gutter'. It is not necessary to design the downstream box gutter.
4. The 'critical box gutter' is designed (in accordance with figure H.1 of AS/NZS 3500.3) for the the catchment area to this gutter, plus any additional catchment area flowing directly into the downstream box gutter.
5. The total flow rate in all gutters must not exceed the Maximum Design Flow rate in the table.
6. All Junctions are supplied as 'Sliding' Junctions (i.e. supplied in two-piece / adjustable) by default. Sliding Junctions are able to contract for the upstream box gutter width within the specified range (all sizes except 200)
7. 'Fixed' Junctions are also available for special larger volume orders (over 20 units), however Fixed Junctions are not adjustable for the upstream box gutter.
8. **ONLY THE UPSTREAM BOX GUTTERS MAY BE CONTRACTED. THE DOWNSTREAM BOX GUTTER MAY NOT BE NARROWER THAN THE UPSTREAMS BOX GUTTER.**



7. INSTRUCTIONS FOR INSTALLATION

Dam Buster products must be installed in accordance with the Dam Buster Installation Manual. Additionally, roof drainage installations should comply with Section 4 of AS/NZS 3500.3 '*Roof drainage systems – Installation*'. It is the licensed roof plumber's responsibility to certify all works associated with the installation of the box gutters and Dam Buster devices in accordance with the specific requirements of that State or Territory.

Overflow pipes to the Dam Buster Sump must discharge visibly to atmosphere, in order to alert the building owner / occupant to a blockage. Where possible, the Dam Buster Sump should also be fitted with a 90mm diameter 'Full Blockage Overflow Indicator', as shown on the standard detail sheets. This overflow indicator is supplied by the installing plumber typically fitted on the end wall of the sump but may also be fitted on a side wall (so long as the centreline of the pipe is level with the sole of the box gutter). There may be situations where it is not possible or desirable to incorporate the Full Blockage Overflow Indicator, and the building designer and plumber should consider this on a case by case basis. Note, that the Dam Buster Sump has a similar safeguard with regards to blockage as the DTS Sump / High Capacity overflow device, and the Full Blockage Overflow indicator is recommended for additional safety.

8. RISK MANAGEMENT (DESIGN) & MAINTENANCE OF BOX GUTTER SYSTEMS

There are numerous ways in which the risk of failure of box gutter systems can be minimized. Refer to Appendix E for a discussion on Risk Management (Design).

Regular maintenance of box gutter systems is essential to ensure they continue to function as intended. The frequency of maintenance required will depend on the presence and type of nearby vegetation, and other factors such as prevailing wind directions and vulnerability to debris, rubbish, nesting material etc. For example, more regular maintenance may be required for school buildings, where balls may block downpipes. Refer also Appendix E for further discussion on the maintenance of box gutter systems.



9. INTELLECTUAL PROPERTY AND KNOW-HOW

Dam Buster is a registered Trademark both in Australia and Overseas, and all Dam Buster products are also protected by a comprehensive range of Australian and Overseas patents. Breaches of Intellectual Property and Know-How rights are serious and will be pursued by Dam Buster Pty Ltd and Dam Buster IP Pty Ltd against any infringers.

With the exception of the AHSCA-RF Overflow Performance Certificates, Dam Buster has chosen not to make testing data which supports compliance of the Dam Buster products publicly available, due to the documents and information being Dam Buster 'Intellectual Property'.

10. SUPPORT

Refer to Dam Buster's website www.dambuster.com.au

11. APPENDICES

Appendix	Description
A	Dam Buster Products Names
B	Design Example – Dam Buster Rainhead
C	Dam Buster Standard drawing details
D	Dam Buster Product Data Sheets
E	Risk Management (Design) & Maintenance of Box Gutter Systems
F	Box Gutter Design Charts
G	Aerial Downpipe Design Chart



Appendix A

Dam Buster Product Names



Dam Buster Product Names



Label	Name	Sizes					
Rainheads							
R-www	Rainhead	R-200	R-300	R-400	R-500	R-600	
CR-www	Curved Rainhead	CR-200	CR-300	CR-400	CR-500	CR-600	
R-www-FB	Flat Back Rainhead	R-200-FB	R-300-FB	R-400-FB	R-500-FB	R-600-FB	
CR-www-FB	Flat Back Curved Rainhead	CR-200-FB	CR-300-FB	CR-400-FB	CR-500-FB	CR-600-FB	
Stretched Rainheads							
R-200-www	Stretched R-200 Rainhead ⁽¹⁾	R-200-300	n/a				
R-200-www-FB	Stretched Flat Back R-200 Rainhead ⁽¹⁾	R-200-300-FB	n/a				
R-300-www	Stretched R-300 Rainhead ⁽¹⁾	n/a	R-300-350 R-300-380	R-300-400 R-300-450	R-300-500	R-300-600	
R-300-www-FB	Stretched Flat Back R-300 Rainhead ⁽¹⁾	n/a	R-300-350-FB R-300-380-FB	R-300-400-FB R-300-450-FB	R-300-500-FB	R-300-600-FB	
Widened Rainheads							
WR-www	Widened Rectangular Rainhead ⁽²⁾	WR-200	WR-300	n/a	n/a	n/a	
Maxi Rainheads							
R-www-MX	Maxi Rainhead ⁽³⁾	n/a	R-300-MX	n/a			
CR-www-MX	Maxi Curved Rainhead ⁽³⁾	n/a	CR-300-MX	n/a			
R-www-MX-FB	Maxi Flat Back Maxi Rainhead ⁽³⁾	n/a	R-300-MX-FB	n/a			
CR-www-MX-FB	Maxi Curved Flat Back Rainhead ⁽³⁾	n/a	CR-300-MX-FB	n/a			
Mini Rainheads							
MR-www	Mini Rainhead ⁽⁴⁾	MR-200	n/a				
MCR-www	Mini Curved Rainhead ⁽⁴⁾	MCR-200	n/a				
MR-www-FB	Mini Flat Back Rainhead ⁽⁴⁾	MR-200-FB	n/a				
MCR-www-FB	Mini Curved Flat Back Rainhead ⁽⁴⁾	MCR-200-FB	n/a				
Sumps							
SU-www-ddd	Sump	Width	200	300	400	500	600
		Depth		SU-300-75			
		75					
		100	SU-200-100				
		125		SU-300-125			
	150	SU-200-150		SU-400-150	SU-500-150	SU-600-150	
	200		SU-300-200	SU-400-200	SU-500-200	SU-600-200	
Side Outlets							
TSO-www	T Side Outlet	TSO-200	TSO-300	TSO-400	Expansion ranges 200 series – 200mm to 350mm 300 series – 300mm to 450mm 400 series – 400mm to 600mm <i>Note</i> - For the CSO and XSO, only the box gutters parallel to the parapet wall are expandable.		
ESO-www-L	End Side Outlet, LH	ESO-200-L	ESO-300-L	ESO-400-L			
ESO-www-R	End Side Outlet, RH	ESO-200-R	ESO-300-R	ESO-400-R			
CSO-www-L	Corner Side Outlet, LH	CSO-200-L	CSO-300-L	CSO-400-L			
CSO-www-R	Corner Side Outlet, RH	CSO-200-R	CSO-300-R	CSO-400-R			
XSO-www	Cruciform Side Outlet	XSO-200	XSO-300	XSO-400			
Elbows							
ELB-www-L	Elbow, LH	ELB-200-L	ELB-300-L	ELB-400-L	ELB-500-L	ELB-600-L	
ELB-www-R	Elbow, RH	ELB-200-R	ELB-300-R	ELB-400-R	ELB-500-R	ELB-600-R	
Junctions							
TJN-www	T Junction	TJN-200	TJN-300	TJN-400	Contraction ranges for Elbows and Junctions Refer to the Standard drawing details for contraction ranges		
CJN-www-L	Corner Junction, LH	CJN-200-L	CJN-300-L	CJN-400-L			
CJN-www-R	Corner Junction, RH	CJN-200-R	CJN-300-R	CJN-400-R			
Ancillary Products							
BGA-www-WWW	Box Gutter Adaptor	Height = 200mm	BGA-200-300		n/a		
		Height = 250mm	n/a	BGA-300-600			
CL-www	Chute Lid	CL-200	CL-300	CL-400	CL-500	CL-600	
SDC-www	Sump Deflector Cover	SDC-200	SDC-300	SDC-400	SDC-500	SDC-600	
FKC-www	Flashing Kit - Chased flashing		FKC-365	FKC-465		FKC-665	
FKP-www	Flashing Kit - Pressure flashing		FKP-365	FKP-465		FKP-665	
JP-002	Joiner Plates (sold as a pair)	For the Continuous Sump and Back-to-Back Sumps (fits all series 200 to 600)					

NOTES

- Stretched** rainheads. Stretched rainheads (including the box gutter receiver, where applicable) are 'stretched' in the direction perpendicular to the box gutter. All other dimensions remain the same. For example, an R-300-350 is simply an R-300 rainhead, which has been 'stretched' to accommodate a 350mm wide box gutter, rather than a 300mm wide box gutter.
- Widened** rainheads. Widened rainhead are standard rainheads, which have been widened in the direction perpendicular to the box gutter, apart from the box gutter receiver. For example, an WR-200 rainhead fits a 200mm wide box gutter, but has the same width as an R-300 rainhead. This product is suitable for situations where the penetration made in the wall is too large, and the rainhead needs to be widened to cover the penetration.
- Maxi** rainheads. These rainheads are lengthened (only) in the direction of the box gutter and have the same design flow rates as standard rainheads.
- Mini** rainheads. This applies to the 200 series only. This rainhead has a reduced height (and reduced maximum design flowrates).
- Flashing Kits** are supplied as either **Chased ('FKC')** walls flashings or **Pressure ('FKP')** wall flashings.
- All **Side Outlets** and Elbows are supplied as '**Sliding**' (i.e. two-piece / adjustable). However, these products can also be supplied as '**Fixed**' (i.e. one-piece) for special larger volume orders (over 20 units).
- Refer to the **Product Data sheets** in Appendix D of the Product Technical Statement for all dimensions.

Types of Dam Buster Rainheads

The examples below are based on the 300 series of Dam Buster rainheads.

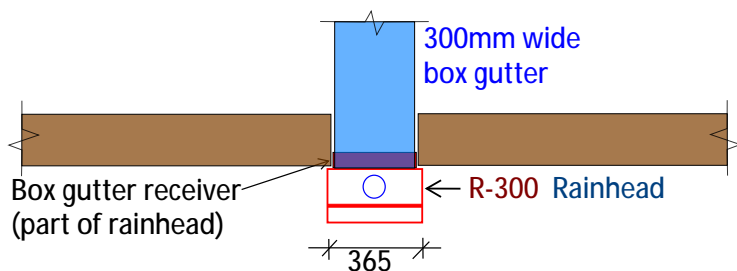

Standard Rainhead

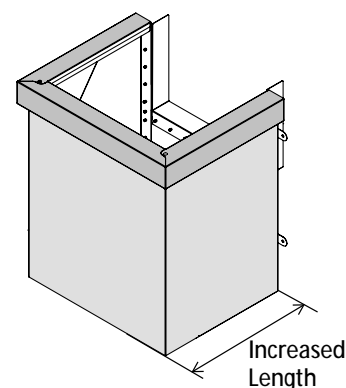

Maxi Rainhead

- 300 Series only
- Standard rainhead with **increased length**
- Designed as per standard rainheads
- Useful for upper floors where the upper external wall is set back slightly from the lower floor wall due to different cladding types eg brick veneer to lower floor and lightweight panels to upper floor.

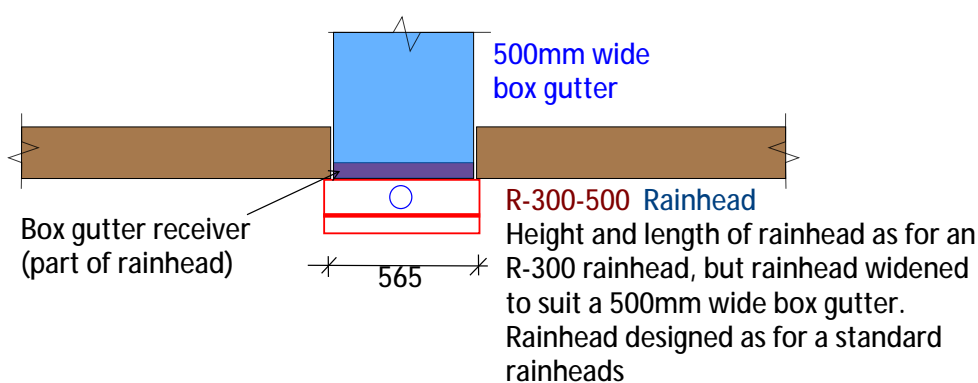

Stretched Rainhead

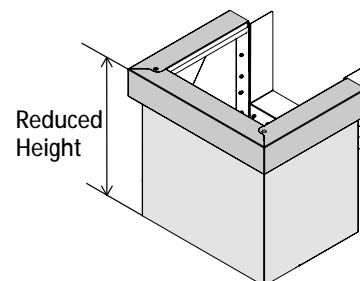

Mini Rainhead

- 200 Series only
- Standard rainhead with **reduced height**
- Reduced maximum flow rate
- Suits small roof areas eg porticos
- Flat back version suits eaves gutters
- Do **not** use with Side Outlets due to reduce depth of box gutter receiver of 150mm

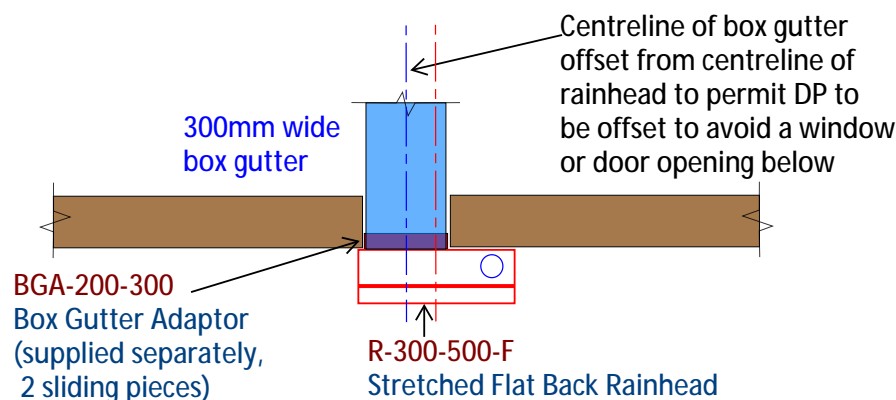

Stretched Flat Back Rainhead fitted with a Box Gutter Adaptor

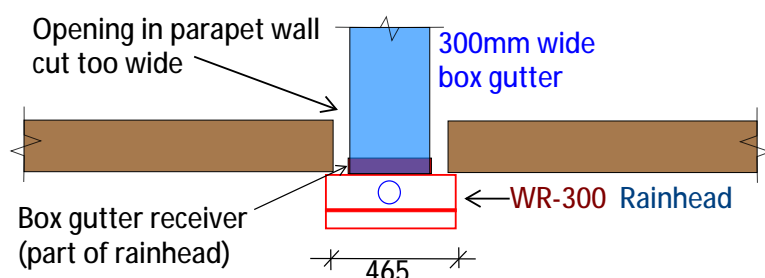

Widened Rainhead

NOTE
Sizes are examples only

Dam Buster Flashing Kits

Flashing kits are available for installations where the opening in the parapet wall has been made too large, requiring a wall flashing to be installed above the rainhead.

There are two types of flashing kits available, one for where the flashing is chased into the wall, and the other where a pressure flashing is used. There are 3 x sizes available for each Flashing Kit - refer to the Dam Buster Product Names table in this document for the available sizes, and to the Product Data Sheets for full dimensions.

These flashings should be installed in accordance with section 8 of SA HB39-2015 *Installation code for metal roof and wall cladding*. Flashing kits can be adjusted / trimmed to suit the application.

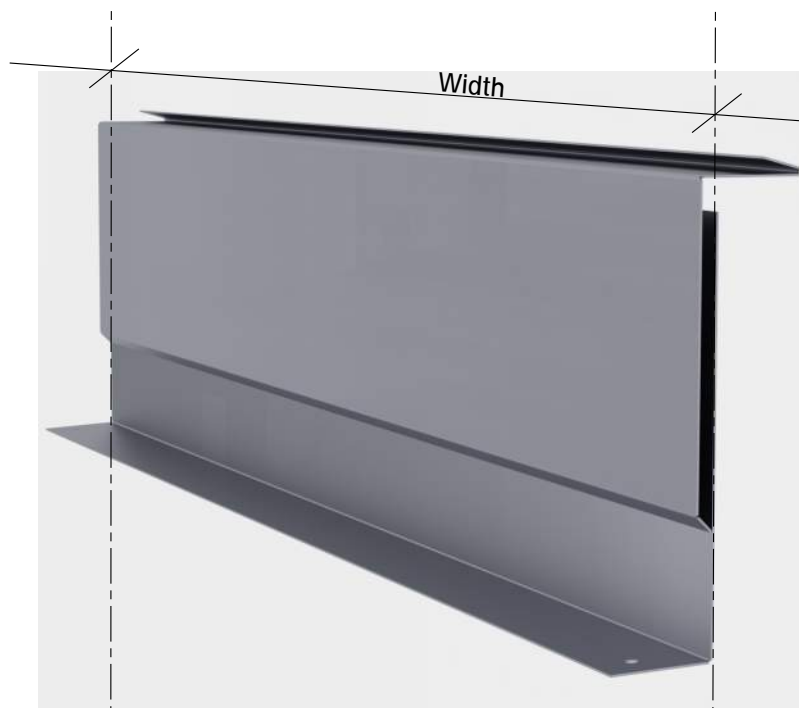

FKC-www
Flashing Kit - Chased flashing



FKP-www
Flashing Kit - Pressure flashing



Appendix B

Design Example – Dam Buster Rainhead



CERTIFIED PRODUCT (DAM BUSTER RAINHEAD)
For testing of the Overflow, Performance of Dam Buster rectangular rainheads.

Roof Drainage Design & Rainhead Selection Example

DAM BUSTER

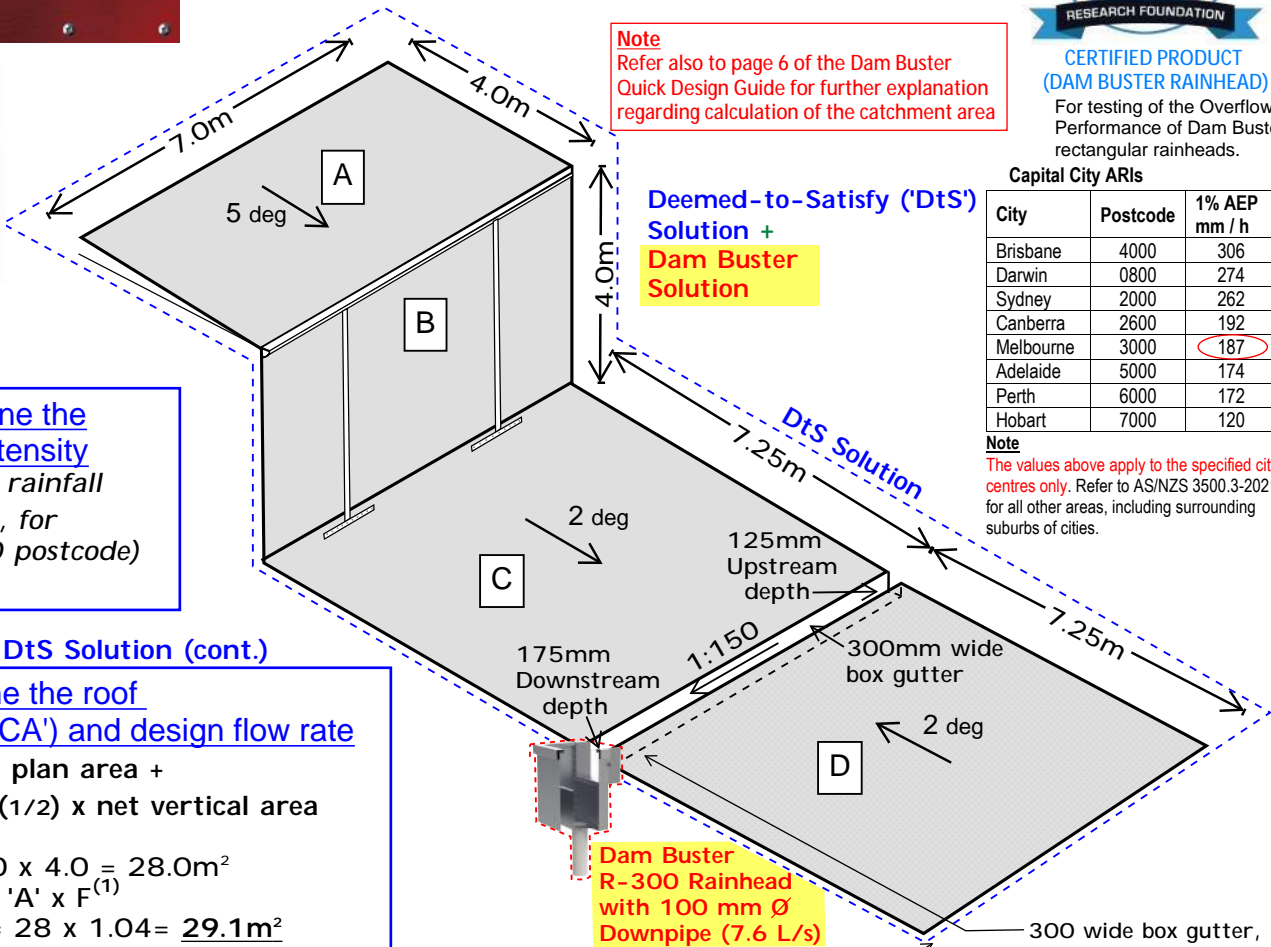

Note
Refer also to page 6 of the Dam Buster Quick Design Guide for further explanation regarding calculation of the catchment area

Deemed-to-Satisfy ('DtS') Solution + Dam Buster Solution

Capital City ARIs

City	Postcode	1% AEP mm / h
Brisbane	4000	306
Darwin	0800	274
Sydney	2000	262
Canberra	2600	192
Melbourne	3000	187
Adelaide	5000	174
Perth	6000	172
Hobart	7000	120

Note
The values above apply to the specified city centres only. Refer to AS/NZS 3500.3-2021 for all other areas, including surrounding suburbs of cities.

DtS Solution

Step 1 - Determine the design rainfall intensity
Adopt the design rainfall intensity, 1%AEP, for Melbourne (3000 postcode) of 187mm/h.

DtS Solution (cont.)

Step 2 - Determine the roof catchment area ('CA') and design flow rate

Catchment Area = plan area + (1/2) x net vertical area

Roof A
Roof area 'A' = 7.0 x 4.0 = 28.0m²
Catchment area = 'A' x F⁽¹⁾
= 28 x 1.04 = **29.1m²**

Wall B
Wall area 'B' = 7.0 x 4.0 = 28.0m²
Catchment Area = 1/2 x 28.0 = **14.0m²**

Roofs C & D
Roof area = 2 x 7 x 7.25 = 101.5m²
Catchment Area = **101.5m²**

Total Catchment Area = **144.6m²**

Q = (CA x 1% AEP) / 3600
= (144.6 x 187) / 3600
= 7.51 litres / sec

DtS Solution (cont.)

Step 3 - Design the (300mm W) box gutter ('BG')

From Figure H.1 of AS/NZS 3500.3, a slope of 1 in 150⁽²⁾, and a flow rate of 7.51 L/s, the design upstream BG depth is 122mm (rounded to 125mm) (OR refer to Appendix F of the Product Technical Statement for BG design charts). The fall over 7.0m is 7000/150=47mm (rounded to 50mm).

ADOPT
300mm wide x (125 min to 175 max) deep BG

Dam Buster Solution

Step 4 - Select the rainhead & DP combination

Referring to Table 1, select a Dam Buster R-300 Rainhead with a 100mm diameter downpipe.
Q(allowable) = 7.6 L/s > 7.51 L/s => OK

NOTE
The rainhead may be either a R-300 or CR-300 Refer also Appendix A of the Product Technical Statement, 'Product Names'.

Dam Buster R-300 Rainhead with 100 mm Ø Downpipe (7.6 L/s)

300 wide box gutter, 1:150 fall, minimum depth designed in accordance with Figure H.1 of AS/NZS 3500.3

Note
The vertical catchment component of the lower roofs, which have the same area, and having equally opposing slopes, cancel each other

CALCULATIONS - NOTE

Steps 1 to 3 are calculations required in relation to the DtS component of the 'Combination of Solutions'.

Step 4, which is a Selection process only (highlighted in yellow), represents the Dam Buster component.

Step (1) & (2) notes

- Refer to Table 3.4.3.2 of AS/NZS 3500.3-2021 for the factor 'F'. This factor depends on the roof slope, and takes into account the extra catchment area for the roof due to the slope i.e. half the projected vertical area of the sloping roof.
Note, 'F' can also be calculated: F = 1.0 + 0.5 x tan (slope) (a scientific calculator is required to calculate F)
- Dam Buster recommends a minimum fall of 1 in 150 to allow for possible minor future building movements, particularly on reactive clay sites.

Dam Buster Rainhead Design Table

Downpipe size	Equivalent diameter	Mini RH	Standard Rainhead size ⁽¹⁾				
		MR-200	R-200	R-300	R-400	R-500	R-600
100 x 50	79	3.00	4.00 ⁽²⁾	4.00 ⁽³⁾			
80 diam.	80	3.00	4.00 ⁽²⁾	4.00 ⁽³⁾			
90 diam.	90	4.00	4.70	6.50			
100 x 75	97	4.50	5.00	7.30	8.00		
100 diam.	100	4.50	5.00	7.60	8.80	8.80	
100 x 100	112			8.80	12.0	12.0	
125 diam.	125			9.50	14.2	15.4	15.9
150 x 100	137				15.8	16.0	16.0
150 diam.	150				16.0	16.0	16.0
Overflow Capacity of Device (L/s)			>12.0	>16.0	>16.0	>16.0	>16.0

(1) Curved fronted rainheads CR-www have the same capacity as rectangular rainheads
(2) Capacities determined by testing by the AHSCA Research Foundation
(3) Capacities adopted for R-200 (R-300 not tested yet for these DPs)

Maximum permissible flow rates (litres / sec)



Appendix C

Dam Buster Standard drawing details

NOTE

All Dam Buster products are protected by various Australian and International Patents. Refer to www.dambuster.com.au to order, and for the following documents:

- Product Technical Statement
- Evidence of Suitability
- Installation Manual

Sheet Number	Page No.	Title
SD001	25	Typical box gutter discharging to a Dam Buster overflow device
SD002	26	Typical Dam Buster Rainhead
SD003	27	Typical Dam Buster Rainhead – Long & deep box gutter
SD004	28	Typical Overflow Device comprising a Dam Buster Rainhead and a Dam Buster Side Outlet
SD004A	29	Section XX through Side Outlet
SD005	30	Dam Buster T Side Outlet & Rainhead combination
SD006	31	Dam Buster End Side Outlet & Rainhead combination (LH)
SD006A	32	Dam Buster End Side Outlet & Rainhead combination (RH)
SD007	33	Dam Buster Corner Side Outlet & Rainhead combination (LH)
SD007A	34	Dam Buster Corner Side Outlet & Rainhead combination (RH)
SD008	35	Dam Buster Cruciform Side Outlet & Rainhead combination
SD009	36	Dam Buster T Side Outlet & Sump combination
SD010	37	Dam Buster End Side Outlet & Sump combination
SD011	38	Dam Buster Corner Side Outlet & Sump combination
SD012	39	Dam Buster Cruciform Side Outlet & Sump combination
SD013	40	Typical Dam Buster Sump
SD013A	41	Typical Continuous Dam Buster Sump
SD014	42	Typical Dam Buster Back-to-Back Sump
SD015	43	Typical Dam Buster Continuous Sump with optional expansion joint
SD015A	44	Section X-X. SD015 – Detail WITHOUT expansion joint
SD015B	45	Section X-X, SD015 – Detail WITH expansion joint
SD0016	46	Dam Buster Sump used in lieu of rainhead – Option A
SD0017	47	Dam Buster Sump used in lieu of rainhead – Option B
SD0018	48	Dam Buster Elbow (LH)
SD0018A	49	Dam Buster Elbow (RH)
SD0019	50	Dam Buster Tee Junction
SD0020	51	Dam Buster Corner Junction (LH)
SD0020A	52	Dam Buster Corner Junction (RH)

List of Dam Buster Standard Details

 Dam Buster Pty Ltd www.dambuster.com.au orders@dambuster.com.au		DESIGNED	DRAWN
		CHECKED	
		SCALE NTS @A4	REVISION
		DATE 01.02.2023	4
		JOB No.	SHEET No.
	TITLE: Standard Details Sheets		SD000

NOTE

All Dam Buster® products are protected by various Australian and International Patents. Refer to www.dambuster.com.au to order, and for the following documents:
 - Product Technical Statement
 - Evidence of Suitability
 - Installation Manual

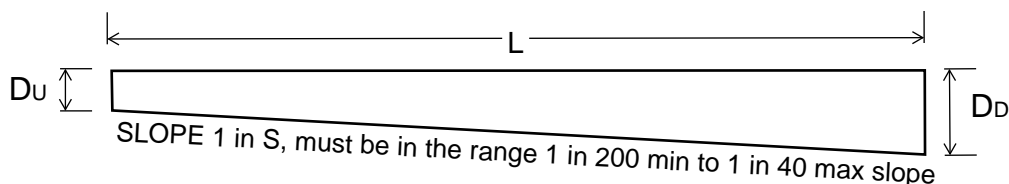
**Typical box gutter profile**

Box gutter sizes are specified as:

W_{BG} mm Wide x (D_U MIN to D_D MAX) mm Deep, where:-

W_{BG} = the box gutter width

L = the box gutter length

S = slope (1 in S)

D_U = depth at the upstream end
 = minimum design box gutter depth to AS/NZS 3500.3,
 (rounded up to nearest 5 mm)

D_D = depth at the downstream end
 = the maximum box gutter depth, calculated as
 $D_u + L / S$ (also rounded up to the nearest 5 mm)

NOTES

- 1) All Dam Buster box gutters should be designed for a minimum flow rate of 3L/s and a maximum flow rate of 16L/s
- 2) Where the Engineer's drawings specify the upstream and downstream depths, these values take precedence (however, the slope must be within the range 1 in 200 min to 1 in 40 max).
- 3) Roof plumber to check box gutter length on site, and confirm the downstream depth, D_D provides the required / design slope.
- 4) The roof plumber may increase the downstream depth, D_D as necessary, however, the minimum depth at the upstream end, D_U, cannot be reduced (and the fall must not exceed 1 in 40).
- 5) For buildings constructed in reactive clay soils, consideration should be given to increasing the box gutter slope in order to allow for potential building movements due to differential changes in foundation soil moisture contents. Dam Buster recommends a minimum slope of 1 in 150 for reactive clay sites.

SD001 - Typical box gutter discharging to a Dam Buster overflow device (NTS)

DAM BUSTER®

Dam Buster Pty Ltd
www.dambuster.com.au
orders@dambuster.com.au

TITLE: **Standard Details Sheets**

DESIGNED	DRAWN
CHECKED	
SCALE NTS @A4	REVISION
DATE 01.02.2023	4
JOB No.	SHEET No.
	SD001

NOTE
 The 150mm minimum only applies for a straight box gutter discharging to a Dam Buster rainhead.
 For the **Dam Buster Side Outlet** and **Rainhead** combinations, the short 'outlet' box gutter is **DEEPER** and requires a **DEEPER** penetration in the parapet wall.

Trim walls of box gutter receiver to equal box gutter depth at downstream end, however, maintain 150mm minimum height through the parapet wall

Dam Buster Chute Lid / flashing*, installed **WITHIN** the box gutter (sold separately).
 * This flashing forms part of the box gutter (not the rainhead) and may instead be folded up on site by roof plumber. Note that Chute Lids are only supplied with Dam Buster Side Outlets.
Note - Fold up Chute Lid at parapet wall and rivet and silicone to hanging flashing.

Hanging flashing recommended

3 deg inwards fall

Parapet capping, installed in accordance with SA HB39

External / parapet wall

Dam Buster rainhead as specified

Box gutter as specified

Box gutter receiver

Overflow condition

NOTE
 Dam Buster recommends a minimum clearance height through the parapet wall as part of Dam Buster's risk minimization strategy.

Note
 All laps must be in the direction of flow

Dam Buster Rainhead sizes
 MR-200, R-200, R-300, R-400, R-500 & R-600

Dam Buster Stretched & Widened Rainheads
 Refer Product Names for available sizes

Dam Buster Curved Rainhead sizes
 MCR-200, CR-200, CR-300, CR-400, CR-500 & CR-600

Dam Buster Rainhead & Curved Rainhead

Normal flow condition

Downpipe as specified

150 mm MIN

Protected by various Australian and International Patents

SD002 - Typical Dam Buster Rainhead (NTS)

NOTES

1. Refer to the current Dam Buster P/L technical manual for installation details

DAM BUSTER[®]

Dam Buster Pty Ltd
 www.dambuster.com.au
 orders@dambuster.com.au

TITLE: Standard Details Sheets

DESIGNED	DRAWN
CHECKED	
SCALE NTS @A4	REVISION 4
DATE 01.02.2023	
JOB No.	SHEET No. SD002

Trim top of box gutter to level of top of rainhead / box gutter receiver.

NOTES

- 1) The box gutter receiver depth has been set such that it will always exceed the minimum design depth of the box gutter (provided the design flow rate of the Dam Buster rainhead is not exceeded).
- 2) This situation can occur for a long box gutter, which is deep at the downstream end due to the fall in the gutter, and noting that the design / minimum box gutter depth must be provided at the upstream end.

Hanging flashing recommended

3 deg inwards fall

Parapet capping, installed in accordance with SA HB39

External / parapet wall

Dam Buster rainhead as specified

Dam Buster Chute Lid / flashing*, installed WITHIN the box gutter (sold separately).

* This flashing forms part of the box gutter (not the rainhead) and may instead be folded up on site by roof plumber. Note that Chute Lids are only supplied with Dam Buster Side Outlets.

Note - Fold up Chute Lid at parapet wall and rivet and silicone to hanging flashing.

Overflow condition

Normal flow condition

Box gutter as specified

Box gutter receiver

Note
All laps must be in the direction of flow

Dam Buster Rainhead sizes

MR-200, R-200, R-300, R-400, R-500 & R-600

Dam Buster Curved Rainhead sizes

MCR-200, CR-200, CR-300, CR-400, CR-500 & CR-600

Dam Buster Stretched & Widened Rainheads

Refer Product Names for available sizes

Downpipe as specified

Note
All laps must be in the direction of flow

Dam Buster Rainhead & Curved Rainhead

SD003 - Typical Dam Buster Rainhead - Long & deep box gutter (NTS)

NOTES

1. Refer to SD002 for all details not noted

Protected by various Australian and International Patents

DAM BUSTER®

Dam Buster Pty Ltd
www.dambuster.com.au
orders@dambuster.com.au

TITLE: Standard Details Sheets

DESIGNED	DRAWN
CHECKED	
SCALE NTS @A4	REVISION 4
DATE 01.02.2023	
JOB No.	SHEET No.
	SD003

Protected by various Australian and International Patents

Note
All laps must be in the direction of flow

Hanging flashing recommended

Dam Buster Chute Lid / flashing, installed WITHIN the short, deep outlet box gutter (supplied with Side Outlet).

NOTE
Box gutter not to be fixed to structure so that it is free to move



X,
SD004A

Dam Buster Side Outlet with sliding components to accommodate different box gutter width

Box gutter receiver

3 deg inwards fall

Parapet capping, installed in accordance with SA HB39

External / parapet wall

Dam Buster rainhead as specified

Overflow condition

Normal flow condition

Downpipe as specified

Side Outlet Width	Rainhead size	Side Outlet Expansion range
200 mm	R-200 or CR-200	200 to 350 mm
300 mm	R-300 or CR-300	300 to 450 mm
400 mm	R-400 or CR-400	400 to 600 mm

Dam Buster Typical Side Outlet & Rainhead

SD004 - Typical Overflow Device comprising a Dam Buster Rainhead and a Dam Buster Side Outlet (NTS)

NOTES

1. Refer to the current Dam Buster P/L technical manual for installation details

DAM BUSTER®

Dam Buster Pty Ltd
www.dambuster.com.au
orders@dambuster.com.au

TITLE: Standard Details Sheets

DESIGNED	DRAWN
CHECKED	
SCALE NTS @A4	REVISION 4
DATE 01.02.2023	
JOB No.	SHEET No.
	SD004

Note- the Side Outlet depth has been pre-engineered such that it is at least as deep as the minimum design (upstream) box gutter depth

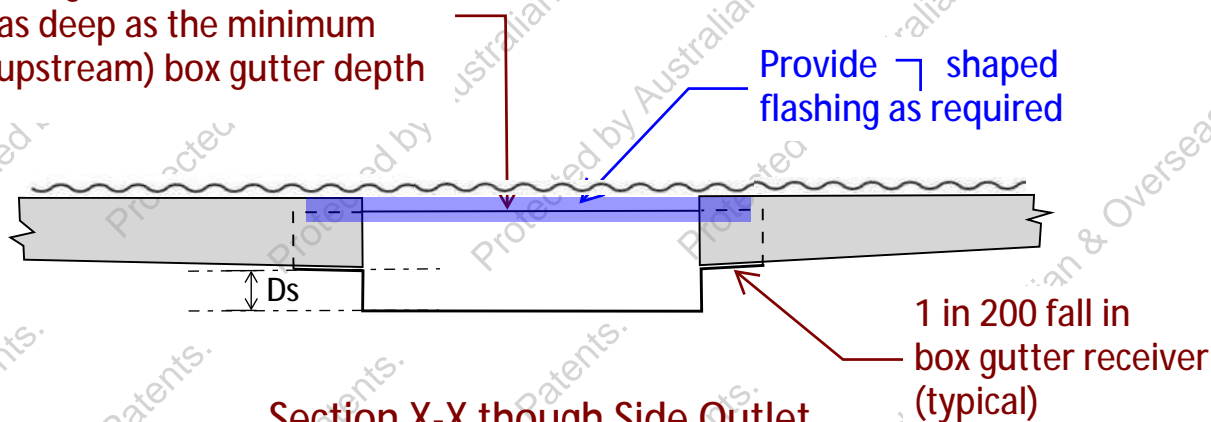

**Section X-X through Side Outlet
Box gutter(s) deeper than Side Outlet**

Side Outlet Width	Side Outlet Depth 'Ds'
200 mm	50 mm
300 mm	60 mm
400 mm	70 mm

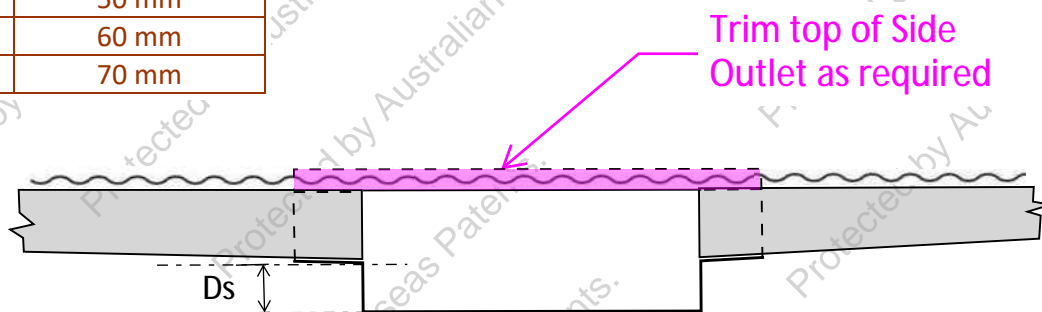

**Section X-X through Side Outlet
Side Outlet deeper than Box gutter(s)**

SD004A - Typical Overflow Device comprising a Dam Buster Rainhead and a Dam Buster Side Outlet (NTS)

NOTES

1. Refer to the current Dam Buster P/L technical manual for installation details

DAM BUSTER[®]

Dam Buster Pty Ltd
www.dambuster.com.au
orders@dambuster.com.au

TITLE: Standard Details Sheets

DESIGNED	DRAWN
CHECKED	
SCALE NTS @A4	REVISION 4
DATE 01.02.2023	
JOB No.	SHEET No.
	SD004A

Protected by various Australian and International Patents

Dam Buster Chute Lid / flashing through external parapet wall, installed WITHIN the short, deep outlet box gutter (i.e. such that Chute Lid sides are placed inside the box gutter and not external to the box gutter).

Note
All laps must be in the direction of flow

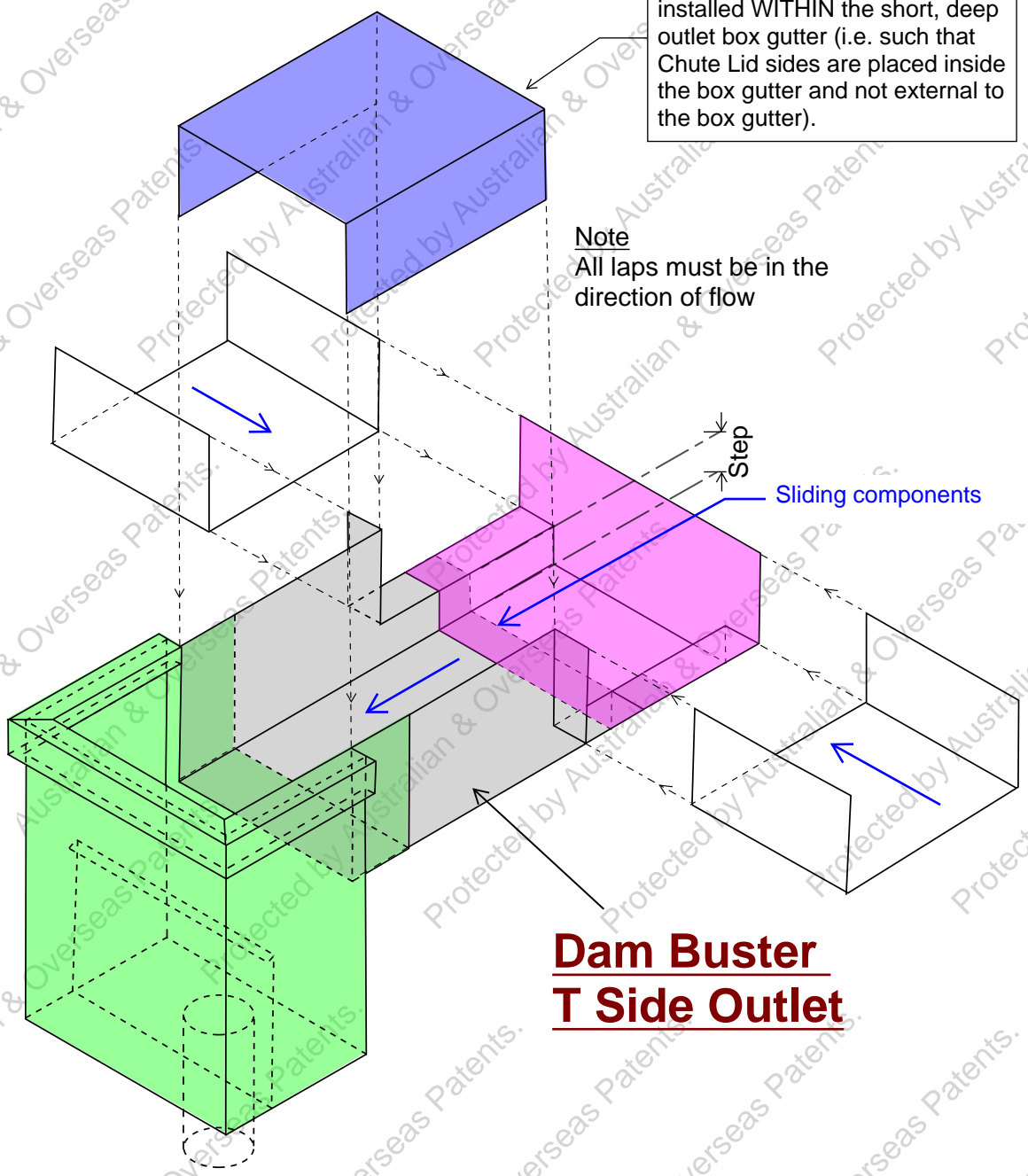

Dam Buster Rainhead

Dam Buster T Side Outlet

T Side Outlet Size	Side Outlet Width	Nominal Step	Rainhead size	Side Outlet Expansion range
TSO-200	200 mm	50mm	R-200 or CR-200	200 to 350 mm
TSO-300	300 mm	60mm	R-300 or CR-300	300 to 450 mm
TSO-400	400 mm	70mm	R-400 or CR-400	400 to 600 mm

SD005 - Dam Buster T Side Outlet & Rainhead combination (NTS)

NOTES

1. Refer to the current Dam Buster manual for installation details

DAM BUSTER[®]

Dam Buster Pty Ltd
www.dambuster.com.au
orders@dambuster.com.au

TITLE: **Standard Details Sheets**

DESIGNED	DRAWN
CHECKED	REVISION
SCALE NTS @A4	4
DATE 01.02.2023	SHEET No.
JOB No.	SD005

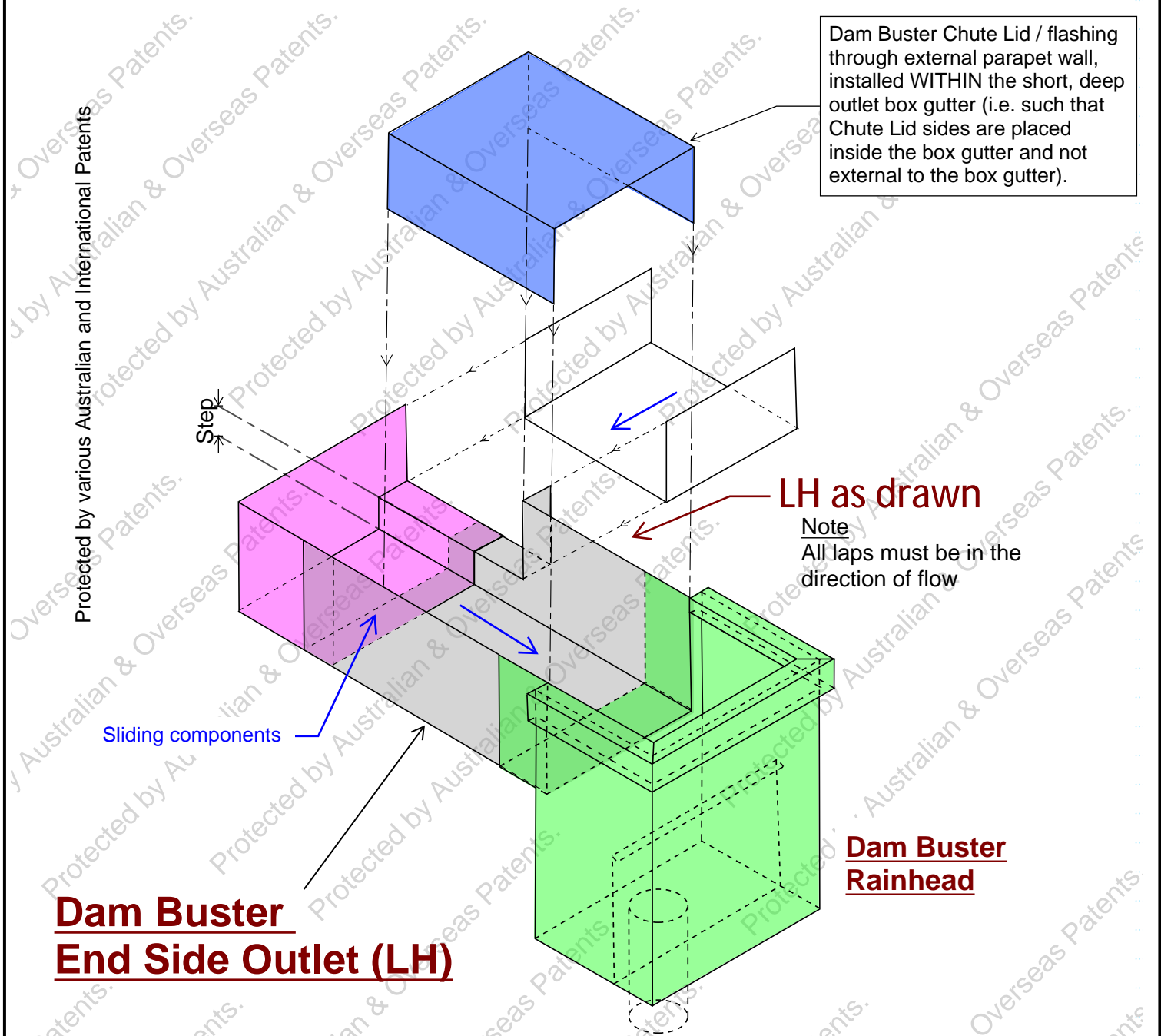

End Side Outlet Size	Side Outlet Width	Nominal Step	Rainhead size	Side Outlet Expansion range
ESO-200-L	200 mm	50mm	R-200 or CR-200	200 to 350 mm
ESO-300-L	300 mm	60mm	R-300 or CR-300	300 to 450 mm
ESO-400-L	400 mm	70mm	R-400 or CR-400	400 to 600 mm

SD006 - Dam Buster End Side Outlet & Rainhead combination (NTS)

NOTES

1. Refer to the current Dam Buster manual for installation details

DAM BUSTER[®]

Dam Buster Pty Ltd
www.dambuster.com.au
orders@dambuster.com.au

TITLE: **Standard Details Sheets**

DESIGNED	DRAWN
CHECKED	REVISION
SCALE NTS @A4	4
DATE 01.02.2023	SHEET No.
JOB No.	SD006

Protected by various Australian and International Patents

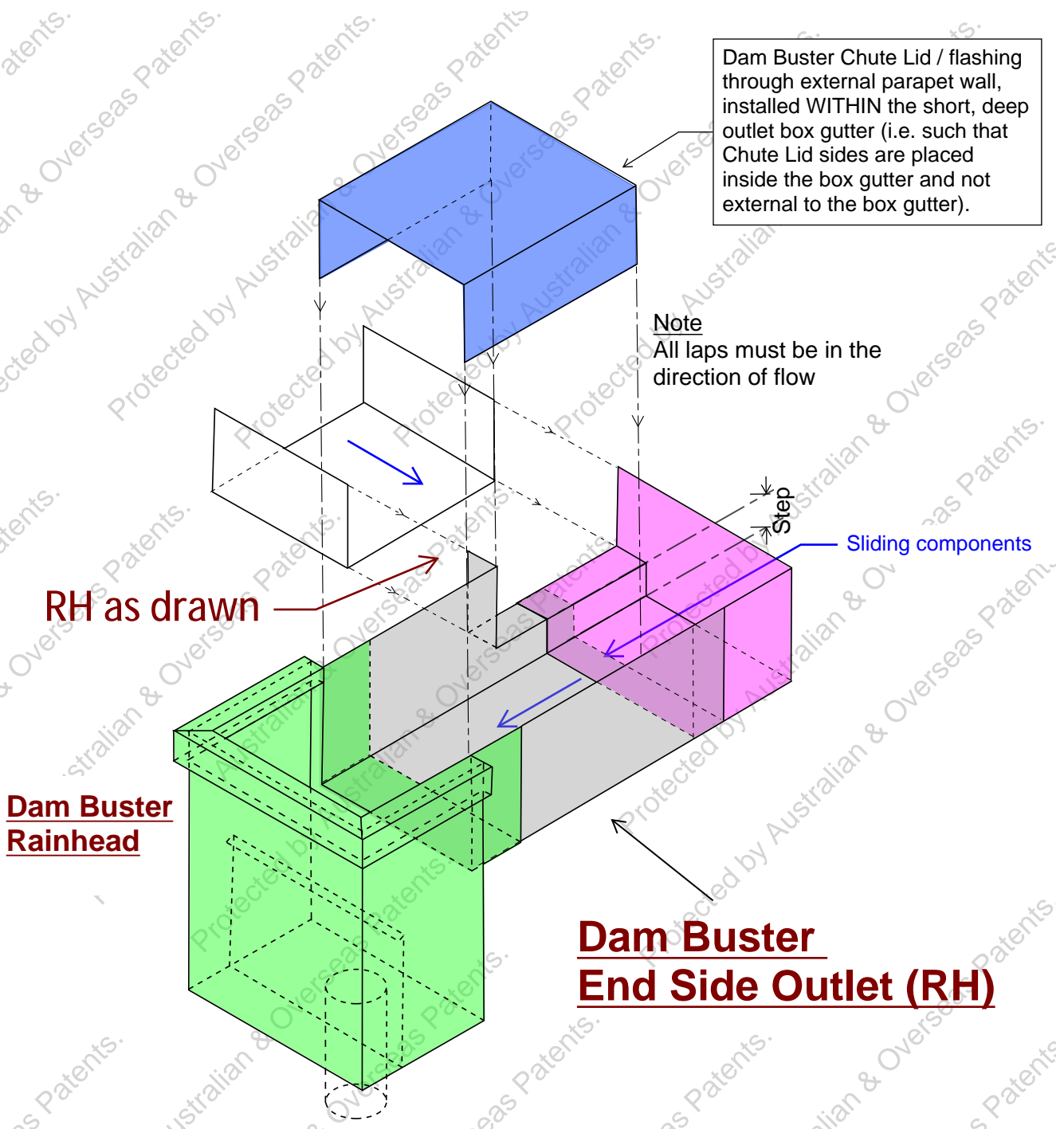

End Side Outlet Size	Side Outlet Width	Nominal Step	Rainhead size	Side Outlet Expansion range
ESO-200-R	200 mm	50mm	R-200 or CR-200	200 to 350 mm
ESO-300-R	300 mm	60mm	R-300 or CR-300	300 to 450 mm
ESO-400-R	400 mm	70mm	R-400 or CR-400	400 to 600 mm

SD006 - Dam Buster End Side Outlet & Rainhead combination (NTS)

NOTES

1. Refer to the current Dam Buster manual for installation details

<h1 style="margin: 0;">DAM BUSTER[®]</h1> <p style="font-size: small; margin: 0;">Dam Buster Pty Ltd www.dambuster.com.au orders@dambuster.com.au</p>		DESIGNED	DRAWN
		CHECKED	
		SCALE NTS @A4	REVISION
		DATE 01.02.2023	4
		JOB No.	SHEET No.
TITLE: Standard Details Sheets		SD006A	

Dam Buster Chute Lid / flashing through external parapet wall, installed WITHIN the short, deep outlet box gutter (i.e. such that Chute Lid sides are placed inside the box gutter and not external to the box gutter).

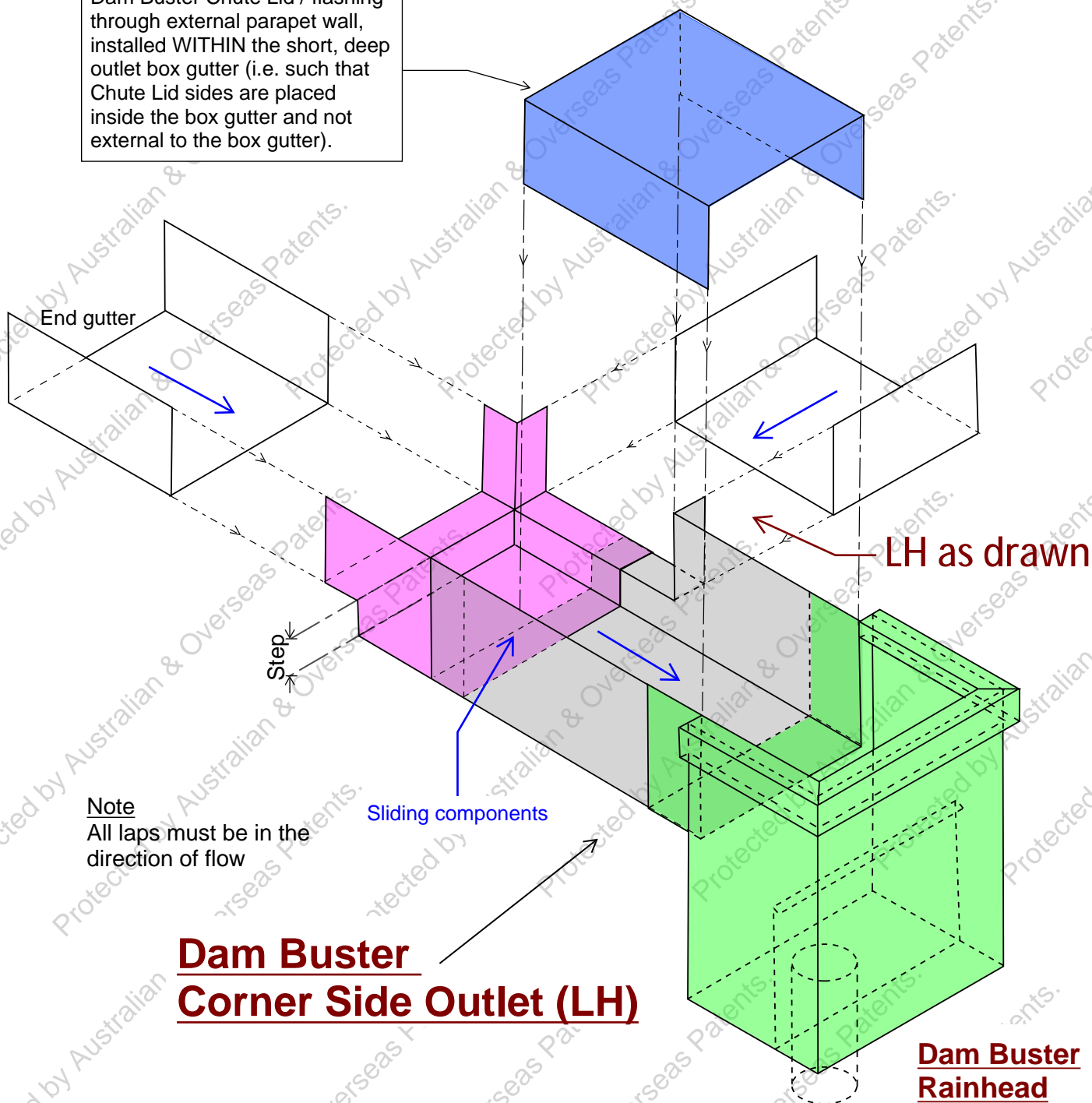

Note
All laps must be in the direction of flow

Sliding components

Dam Buster Corner Side Outlet (LH)

**Dam Buster
Rainhead**

Corner Side Outlet Size	Side Outlet Width	Nominal Step	Rainhead size	Side Outlet Expansion range	End Box Gutter Width
CSO-200-L	200 mm	50mm	R-200 or CR-200	200 to 350 mm	200 mm
CSO-300-L	300 mm	60mm	R-300 or CR-300	300 to 450 mm	300 mm
CSO-400-L	400 mm	70mm	R-400 or CR-400	400 to 600 mm	400 mm

SD007 - Dam Buster Corner Side Outlet & Rainhead combination (NTS)

NOTES

1. Refer to the current Dam Buster manual for installation details

DAM BUSTER[®]

Dam Buster Pty Ltd
www.dambuster.com.au
orders@dambuster.com.au

TITLE: Standard Details Sheets

DESIGNED	DRAWN
CHECKED	
SCALE NTS @A4	REVISION
DATE 01.02.2023	4
JOB No.	SHEET No.
	SD007

Protected by various Australian and International Patents

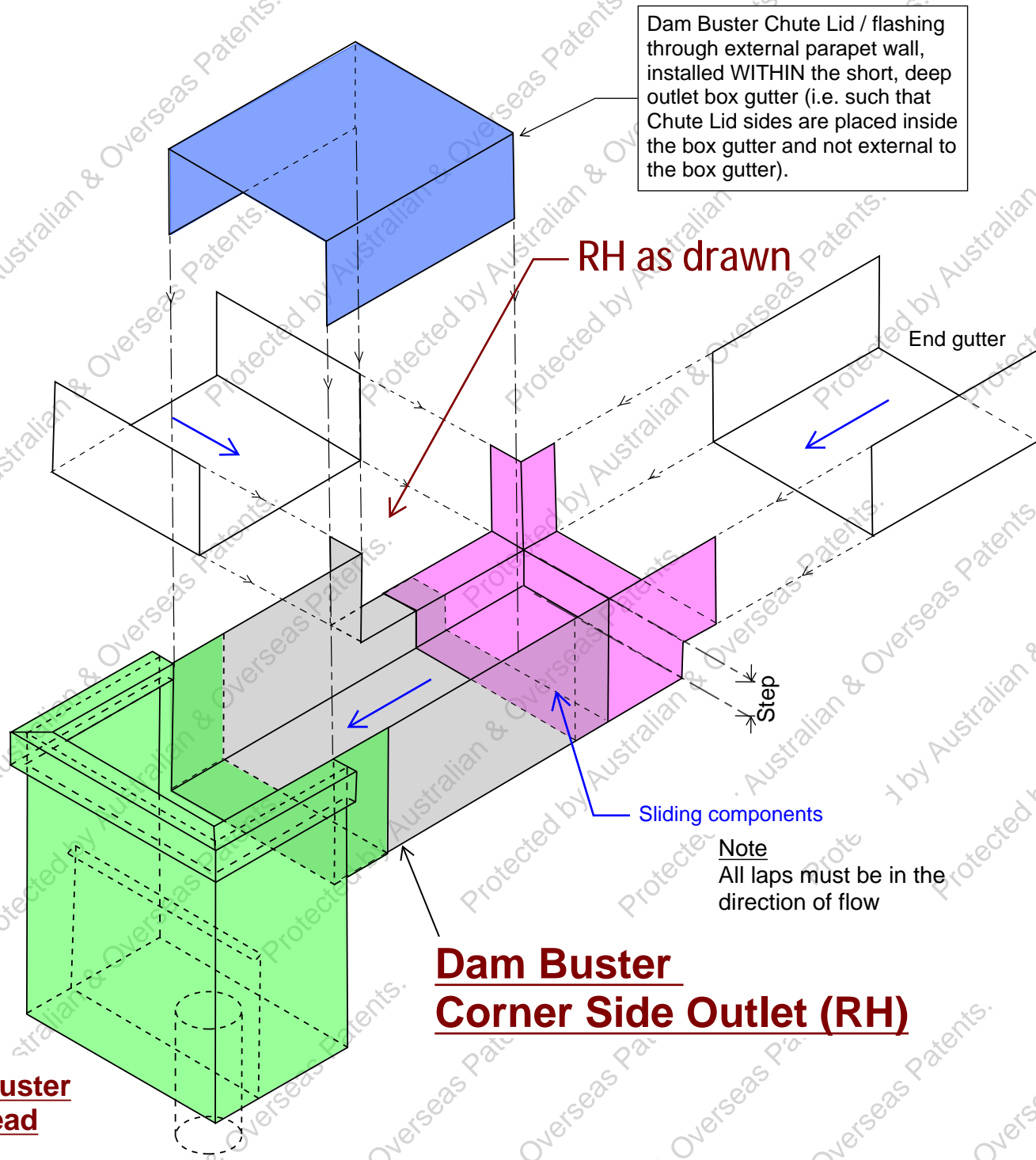

Dam Buster Corner Side Outlet (RH)

Dam Buster Rainhead

Corner Side Outlet Size	Side Outlet Width	Nominal Step	Rainhead size	Side Outlet Expansion range	End Box Gutter Width
CSO-200-R	200 mm	50mm	R-200 or CR-200	200 to 350 mm	200 mm
CSO-300-R	300 mm	60mm	R-300 or CR-300	300 to 450 mm	300 mm
CSO-400-R	400 mm	70mm	R-400 or CR-400	400 to 600 mm	400 mm

SD007 - Dam Buster Corner Side Outlet & Rainhead combination (NTS)

NOTES

1. Refer to the current Dam Buster manual for installation details

DAM BUSTER®

Dam Buster Pty Ltd
www.dambuster.com.au
orders@dambuster.com.au

TITLE: Standard Details Sheets

DESIGNED	DRAWN
CHECKED	
SCALE NTS @A4	REVISION 4
DATE 01.02.2023	
JOB No.	SHEET No.
	SD007A

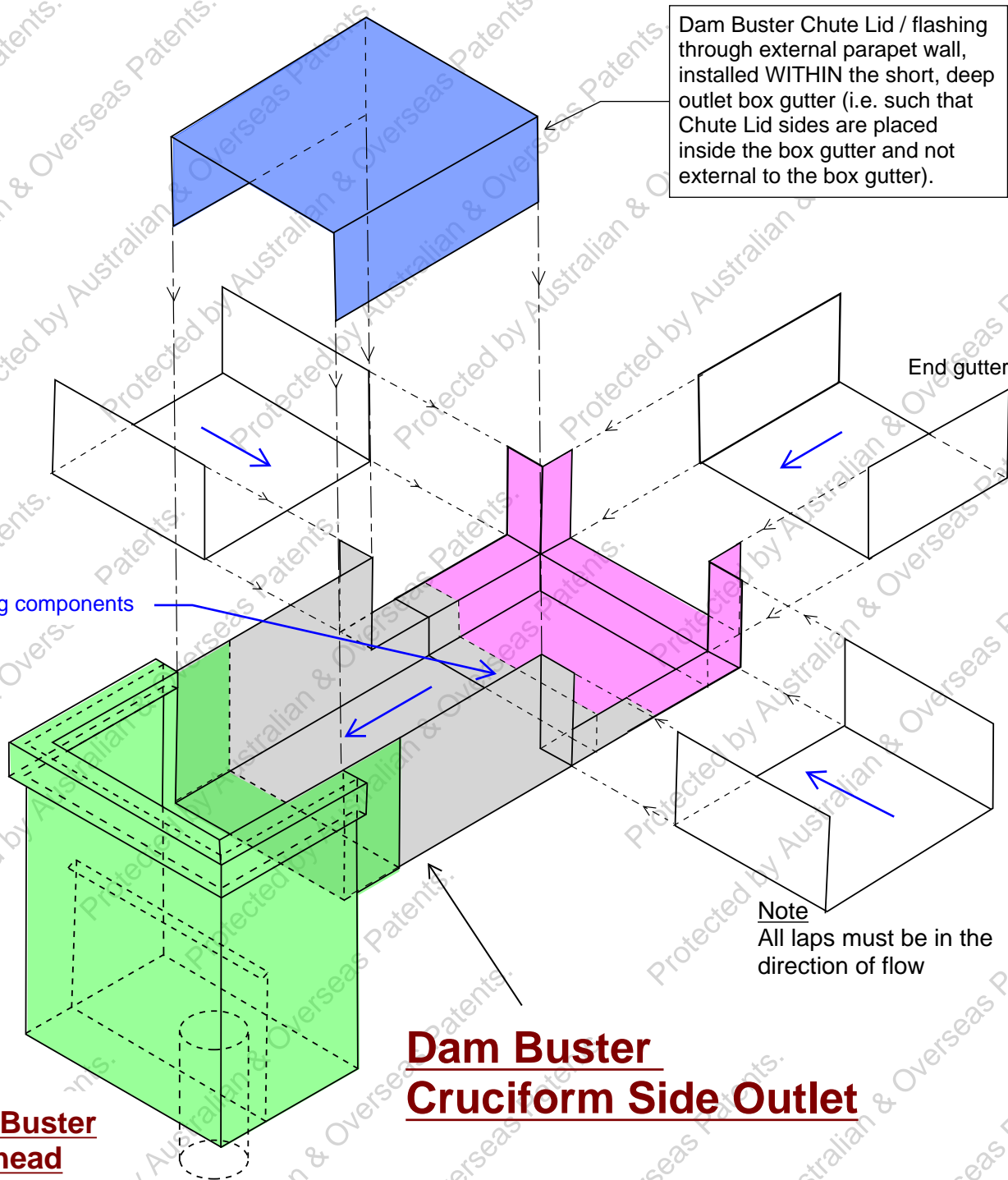

Dam Buster Rainhead

Dam Buster Cruciform Side Outlet

Cruciform Side Outlet Size	Side Outlet Width	Nominal Step	Rainhead size	Side Outlet Expansion range	End Box Gutter Width
XSO-200	200 mm	50mm	R-200 or CR-200	200 to 350 mm	200 mm
XSO-300	300 mm	60mm	R-300 or CR-300	300 to 450 mm	300 mm
XSO-400	400 mm	70mm	R-400 or CR-400	400 to 600 mm	400 mm

SD008 - Dam Buster Cruciform Side Outlet & Rainhead combination (NTS)

NOTES

1. Refer to the current Dam Buster manual for installation details

DAM BUSTER®

Dam Buster Pty Ltd
www.dambuster.com.au
orders@dambuster.com.au

TITLE: Standard Details Sheets

DESIGNED	DRAWN
CHECKED	
SCALE NTS @A4	REVISION 4
DATE 01.02.2023	
JOB No.	SHEET No.
	SD008

Protected by various Australian and International Patents

Protected by various Australian and International Patents

Dam Buster Chute Lid / flashing through external parapet wall, installed WITHIN the short, deep outlet box gutter (i.e. such that Chute Lid sides are placed inside the box gutter and not external to the box gutter).

Note
All laps must be in the direction of flow

Sliding components

NOTE
Refer to the Dam Buster Sump detail for optional Sump Deflector Cover to prevent nuisance flows entering the overflow chamber. Sized to sump width. Sold separately.

Dam Buster Sump

90mm Diam. Overflow Indicator pipe supplied & installed by roof plumber. Note, the Indicator pipe can be alternatively installed to the side of the sump. Refer to Dam Buster Sump detail.

Dam Buster T Side Outlet

T Side Outlet Size	Side Outlet Width	Nominal Step	Sump size	Side Outlet Expansion range
TSO-200	200 mm	50mm	SU-200-100 or SU-200-150	200 to 350 mm
TSO-300	300 mm	60mm	SU-300-125 or SU-300-200	300 to 450 mm
TSO-400	400 mm	70mm	SU-400-150 or SU-400-200	400 to 600 mm

SD009 - Dam Buster T Side Outlet & Sump combination (NTS)

NOTES

1. Refer to the current Dam Buster manual for installation details

DAM BUSTER®

Dam Buster Pty Ltd
www.dambuster.com.au
orders@dambuster.com.au

TITLE: Standard Details Sheets

DESIGNED	DRAWN
CHECKED	
SCALE NTS @A4	REVISION 4
DATE 01.02.2023	
JOB No.	SHEET No.
	SD009

Protected by various Australian and International Patents

Dam Buster Chute Lid / flashing through external parapet wall, installed WITHIN the short, deep outlet box gutter (i.e. such that Chute Lid sides are placed inside the box gutter and not external to the box gutter).

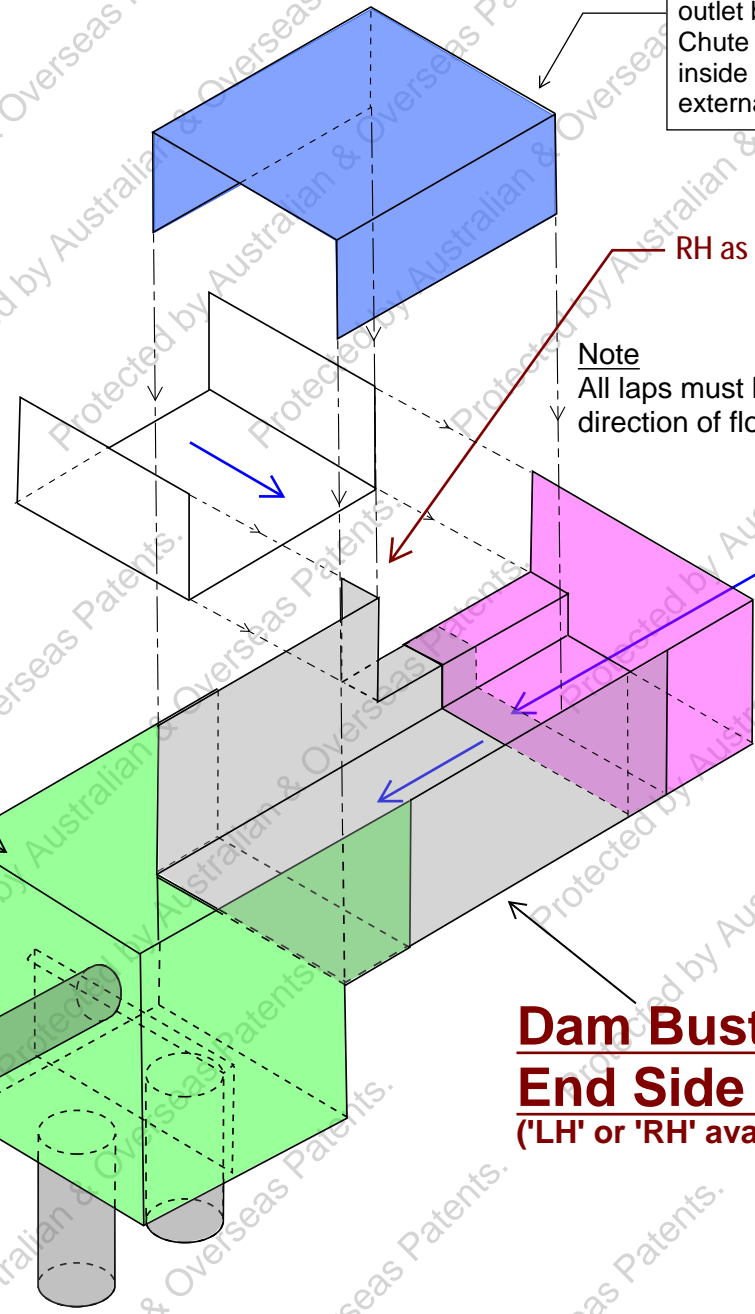

NOTE
Refer to the Dam Buster Sump detail for optional Sump Deflector Cover to prevent nuisance flows entering the overflow chamber

Dam Buster Sump

90mm Diam. Overflow Indicator pipe supplied & installed by roof plumber. Note, the Indicator pipe can be alternatively installed to the side of the sump. Refer to Dam Buster Sump detail.

Dam Buster End Side Outlet (RH)
(‘LH’ or ‘RH’ available)

End Side Outlet Size	Side Outlet Width	Nominal Step	Sump size	Side Outlet Expansion range
ESO-200-(L or R)	200 mm	50mm	SU-200-100 or SU-200-150	200 to 350 mm
ESO-300-(L or R)	300 mm	60mm	SU-300-125 or SU-300-200	300 to 450 mm
ESO-400-(L or R)	400 mm	70mm	SU-400-150 or SU-400-200	400 to 600 mm

SD010 - Dam Buster End Side Outlet & Sump combination (NTS)

NOTES

1. Refer to the current Dam Buster manual for installation details

DAM BUSTER®

Dam Buster Pty Ltd
www.dambuster.com.au
orders@dambuster.com.au

TITLE: Standard Details Sheets

DESIGNED	DRAWN
CHECKED	
SCALE NTS @A4	REVISION 4
DATE 01.02.2023	
JOB No.	SHEET No. SD010

Protected by various Australian and International Patents

90mm Diam. Overflow Indicator pipe supplied & installed by roof plumber. Note, the Indicator pipe can be alternatively installed to the side of the sump. Refer to Dam Buster Sump detail.

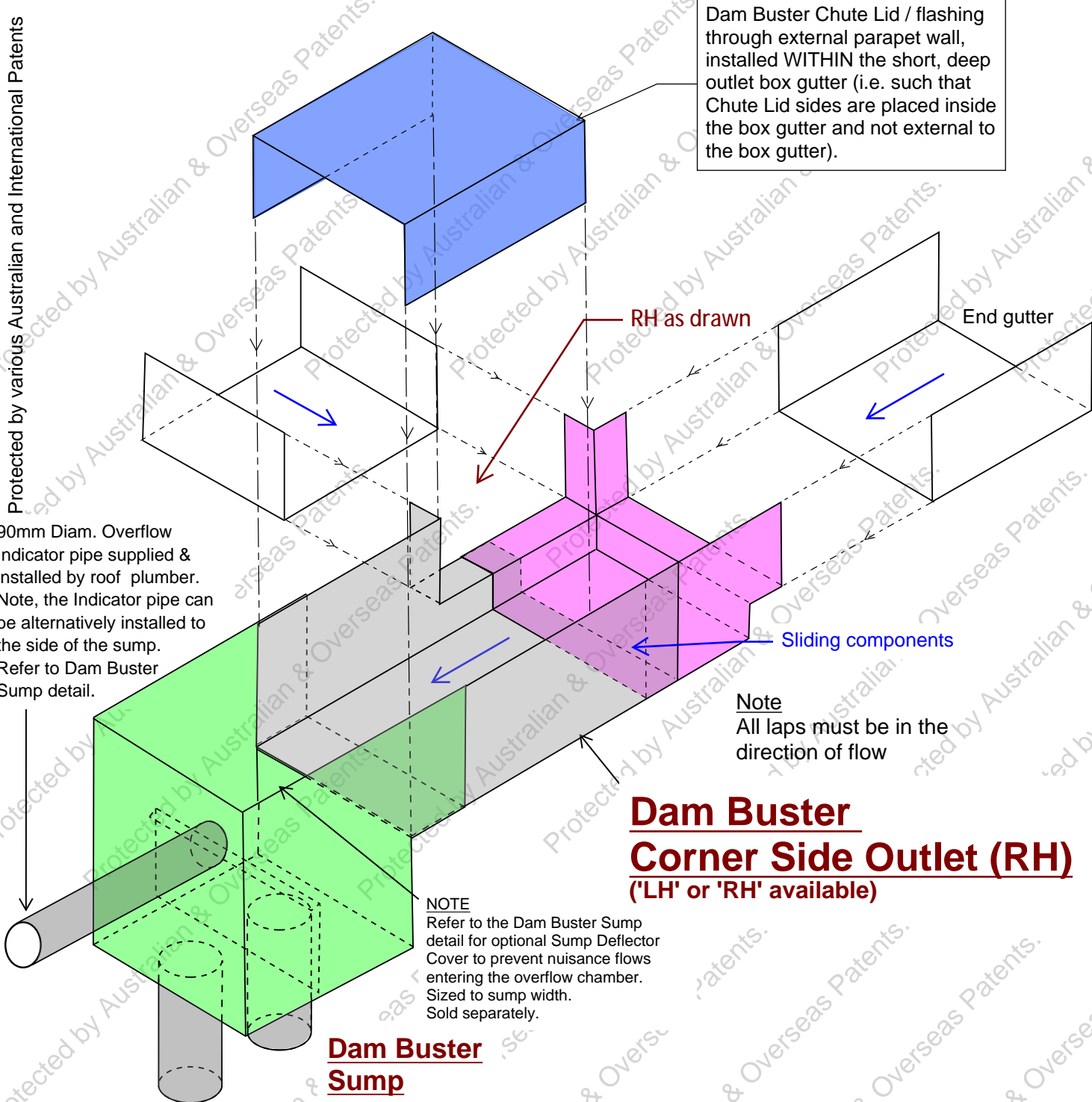

Dam Buster Chute Lid / flashing through external parapet wall, installed WITHIN the short, deep outlet box gutter (i.e. such that Chute Lid sides are placed inside the box gutter and not external to the box gutter).

Dam Buster Corner Side Outlet (RH) ('LH' or 'RH' available)

NOTE
Refer to the Dam Buster Sump detail for optional Sump Deflector Cover to prevent nuisance flows entering the overflow chamber. Sized to sump width. Sold separately.

Dam Buster Sump

Corner Side Outlet Size	Side Outlet Width	Nominal Step	Sump size	Side Outlet Expansion range	End Box Gutter Width
CSO-200-(L or R)	200 mm	50mm	SU-200-100 or SU-200-150	200 to 350 mm	200 mm
CSO-300-(L or R)	300 mm	60mm	SU-300-125 or SU-300-200	300 to 450 mm	300 mm
CSO-400-(L or R)	400 mm	70mm	SU-400-150 or SU-400-200	400 to 600 mm	400 mm

SD011 - Dam Buster Corner Side Outlet & Sump combination (NTS)

NOTES

1. Refer to the current Dam Buster manual for installation details

DAM BUSTER[®]

Dam Buster Pty Ltd
www.dambuster.com.au
orders@dambuster.com.au

TITLE: Standard Details Sheets

DESIGNED	DRAWN
CHECKED	
SCALE NTS @A4	REVISION 4
DATE 01.02.2023	
JOB No.	SHEET No.
	SD011

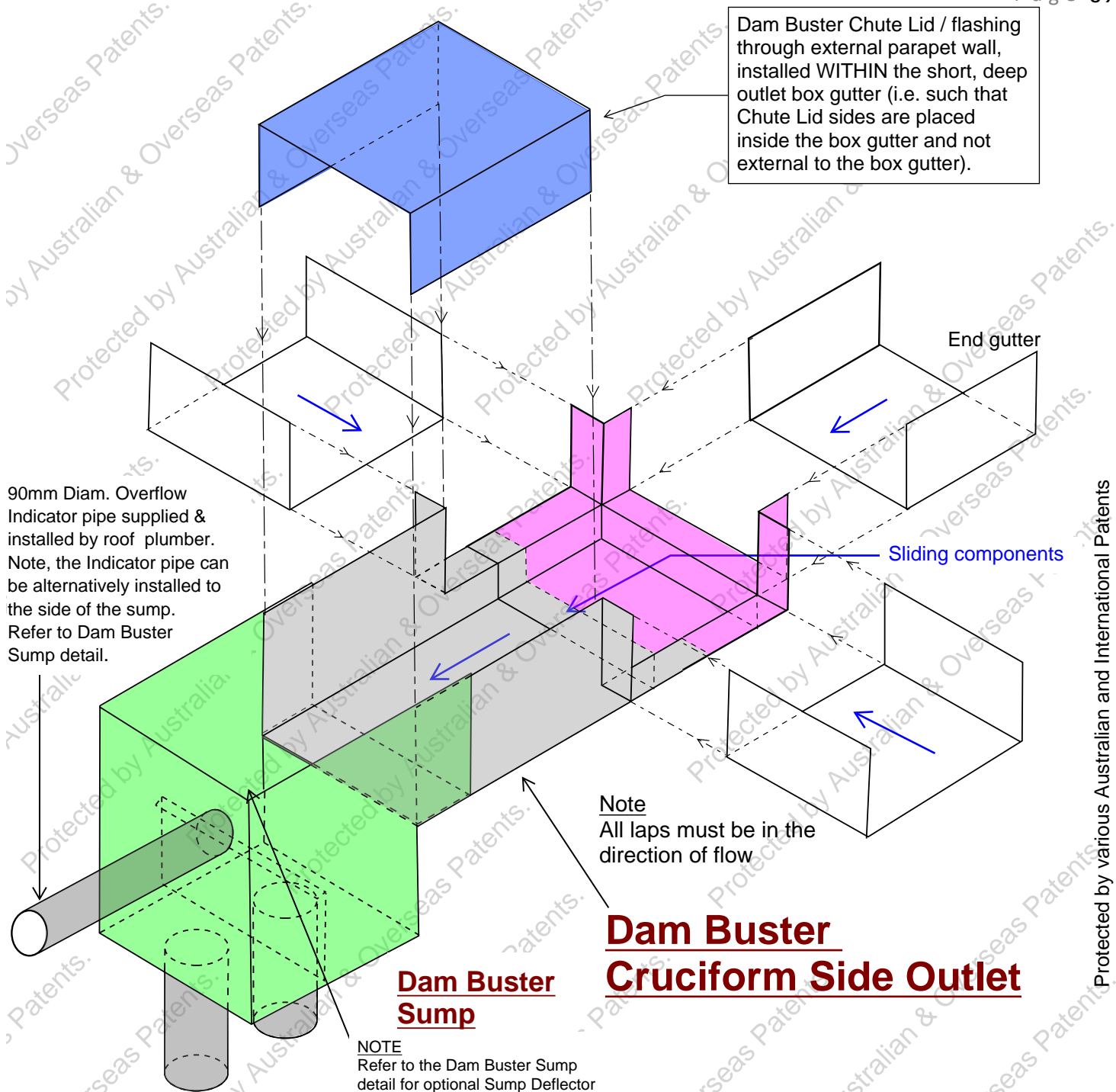

Protected by various Australian and International Patents

Cruciform Side Outlet Size	Side Outlet Width	Nominal Step	Sump size	Side Outlet Expansion range	End Box Gutter Width
XSO-200	200 mm	50mm	SU-200-100 or SU-200-150	200 to 350 mm	200 mm
XSO-300	300 mm	60mm	SU-300-125 or SU-300-200	300 to 450 mm	300 mm
XSO-400	400 mm	70mm	SU-400-150 or SU-400-200	400 to 600 mm	400 mm

SD012 - Dam Buster Cruciform Side Outlet & Sump combination (NTS)

NOTES

1. Refer to the current Dam Buster manual for installation details

DAM BUSTER®

Dam Buster Pty Ltd
www.dambuster.com.au
orders@dambuster.com.au

TITLE: Standard Details Sheets

DESIGNED	DRAWN
CHECKED	
SCALE NTS @A4	REVISION 4
DATE 01.02.2023	
JOB No.	SHEET No.
	SD012

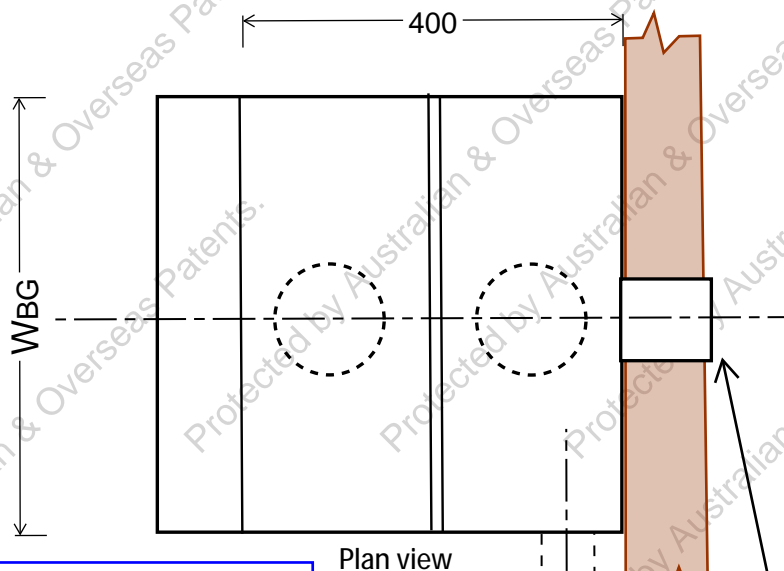

Plan view

NOTE
A full blockage indicator is recommended where possible to indicate blockage has occurred in both the normal downpipe and overflow downpipes

NOTE
If the full blockage overflow cannot be located through the end wall, it can be located through either of the side walls

NOTE
Where a SDC is used, the minimum recommended downstream box gutter depth to enable cleaning is 120mm.

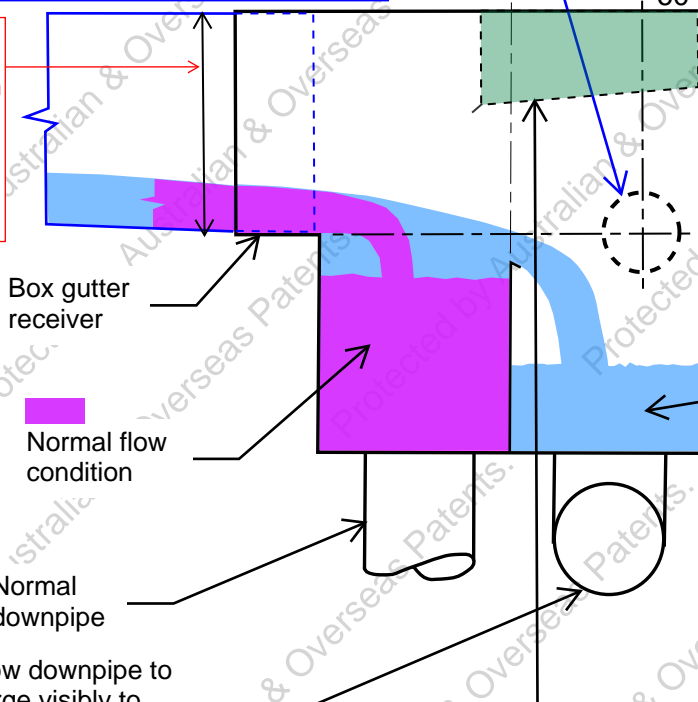

Full blockage indicator 90mm diam pipe (centreline level with the sole of the box gutter).
NOTE
The full blockage overflow pipe is supplied and installed by the roof plumber.

Note
All laps must be in the direction of flow

Dam Buster Sump size

SU-**WWW**-**DDD**

'DDD' refers to sump depth, **DS**

'WWW' refers to Box Gutter Width, **WBG**

Dam Buster Sump Deflector Cover (Optional*)

SDC-**WWW** available for all sump sizes.

Sized to fit sump width. Sold separately.

* The Sump Deflector Cover prevents 'nuisance flows' entering the overflow chamber but may increase maintenance (cleaning) requirements.

SD013 - Typical Dam Buster Sump detail (NTS)

NOTES

1. Refer to the current Dam Buster P/L technical manual for installation details

DAM BUSTER[®]

Dam Buster Pty Ltd
www.dambuster.com.au
orders@dambuster.com.au

TITLE: Standard Details Sheets

DESIGNED	DRAWN
CHECKED	
SCALE NTS @A4	REVISION 4
DATE 01.02.2023	
JOB No.	SHEET No.
	SD013

Protected by various Australian and International Patents

NOTE
Where SDCs are used:
(i) Cut out end wall of downstream box gutter for a depth of 60mm
(ii) Cut corners of SDC and fold down over reduced box gutter end wall.

DAM BUSTER JOINER PLATES BOTH SIDES TO INNER FACES.

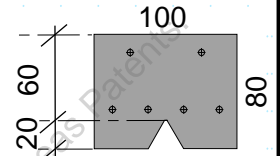
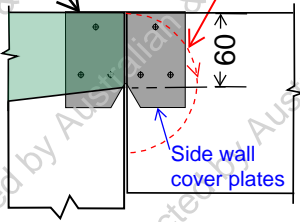

Dam Buster Joiner Plates ('JP-002') dimensions (supplied in pairs)

NOTE
A full blockage overflow indicator is recommended where possible. Refer to typical (non-continuous) Sump detail.

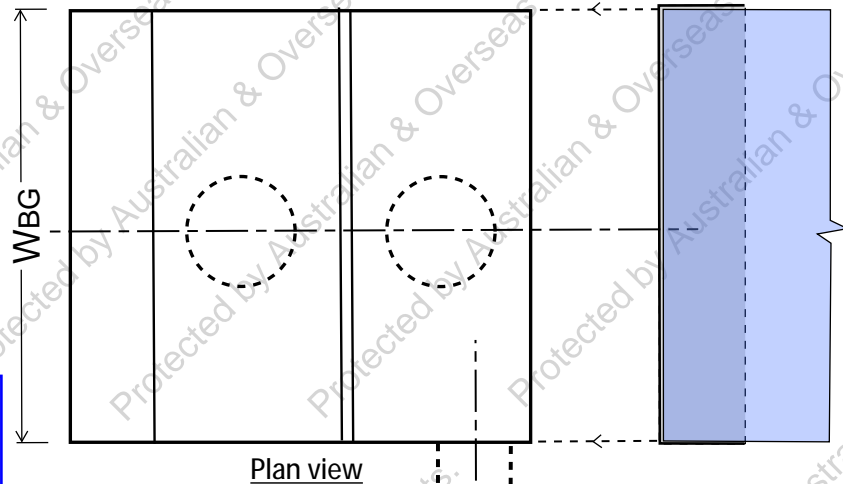

Plan view

Downstream box gutter, refer SD015 for details

NOTE
Where a SDC is used, the minimum recommended downstream box gutter depth to enable cleaning is 120mm.

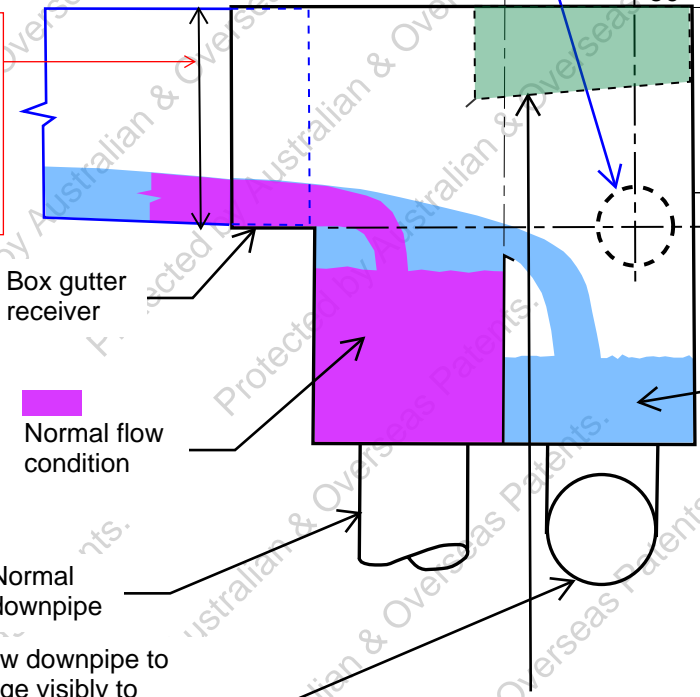

Box gutter receiver

Normal flow condition

Normal downpipe

Overflow downpipe to discharge visibly to atmosphere through a side wall or external soffit

Overflow condition

Downstream box gutter receiver, refer SD015

Note
All laps must be in the direction of flow

Dam Buster Sump size

SU-**WWW**-**DDD**

'DDD' refers to sump depth, **DS**

'WWW' refers to Box Gutter Width, **WBG**

Dam Buster Sump Deflector Cover (Optional*)

SDC-**WWW** available for all sump sizes.

Sized to fit sump width. Sold separately.

* The Sump Deflector Cover prevents 'nuisance flows' entering the overflow chamber but may increase maintenance (cleaning) requirements.

SD013A - Typical Continuous Dam Buster Sump detail (NTS)

NOTES

1. Refer to the current Dam Buster P/L technical manual for installation details

Protected by various Australian and International Patents

DAM BUSTER[®]

Dam Buster Pty Ltd
www.dambuster.com.au
orders@dambuster.com.au

CLIENT:	DESIGNED	DRAWN
PROJECT:	CHECKED	
ADDRESS:	SCALE NTS @A4	REVISION 0
TITLE: Standard Details Sheets	DATE 21.05.2024	
	JOB No.	SHEET No. SD013A

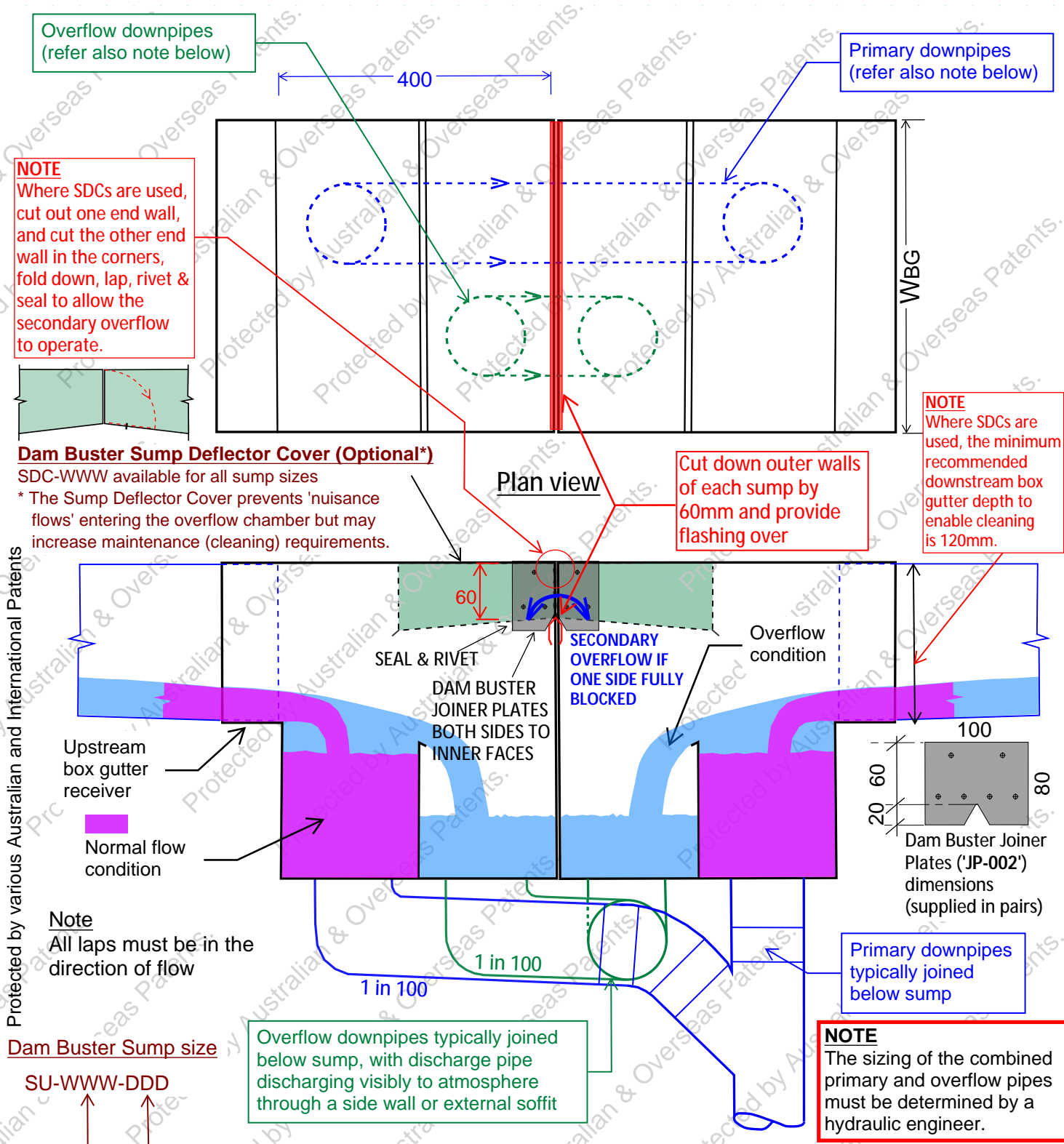

SD014 - Typical Dam Buster Back-to-Back Sump detail (NTS)

- NOTES**
1. Refer also to the Dam Buster P/L Installation Manual.
 2. The hydraulic capacity of the Dam Buster Back-to-Back Sump is double that of a single Dam Buster Sump, however, the aerial overflow pipe must be sized for the total design flow in both box gutters / sumps.

<p>Dam Buster Pty Ltd www.dambuster.com.au orders@dambuster.com.au</p>	DESIGNED		DRAWN
	CHECKED		
	SCALE NTS @A4	REVISION	
	DATE 01.02.2023	4	
	JOB No.	SHEET No.	
TITLE: Standard Details Sheets			SD014

DESIGNED	CHECKED	SCALE	DATE	JOB NO.	SHEET NO.
		NTS @A4	01.02.2023		SD015
DRAWN		REVISION			
		4			

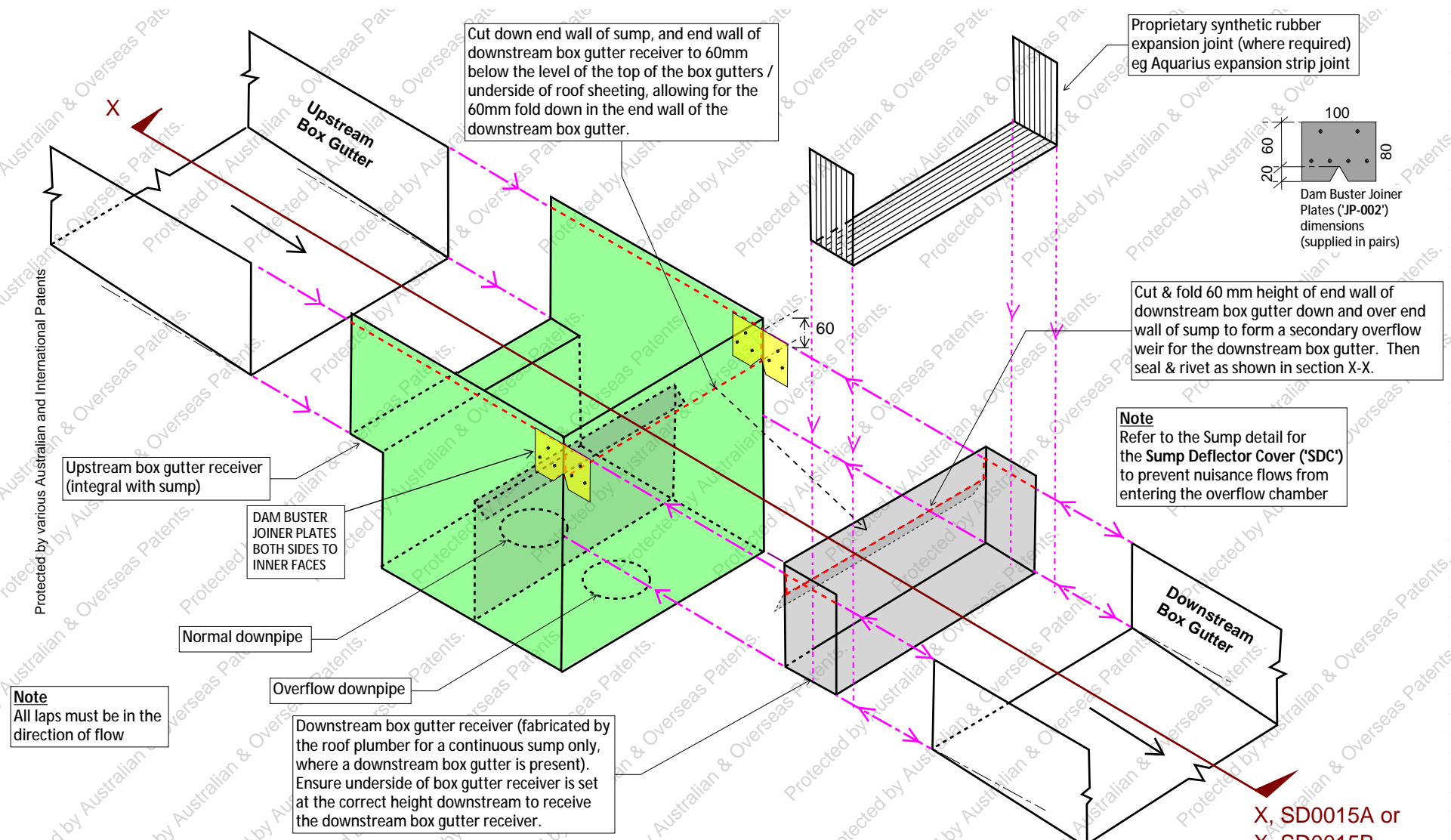

SD015 - Typical Dam Buster Continuous Sump with optional expansion joint detail (NTS)

- NOTES**
1. Refer to the current Dam Buster P/L technical manual for installation details
 2. Refer to detail SD0015A for Continuous Sump, WITHOUT an expansion joint
 3. Refer to detail SD0015B for Continuous Sump, WITH an expansion joint

Note
 Refer to the Sump detail for the **Sump Deflector Cover ('SDC')** to prevent nuisance flows from entering the overflow chamber

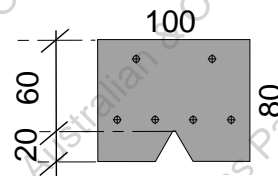

Dam Buster Joiner Plates ('JP-002') dimensions (supplied in pairs)

DAM BUSTER JOINER PLATES INSTALLED ON INNER FACE OF SIDE WALLS

TOP OF SECONDARY OVERFLOW WEIR, FORMED FROM DOWNSTREAM BOX GUTTER RECEIVER, TO BE 60MM LOWER THAN THE TOP OF THE BOX GUTTERS / UNDERSIDE OF ROOF SHEETING

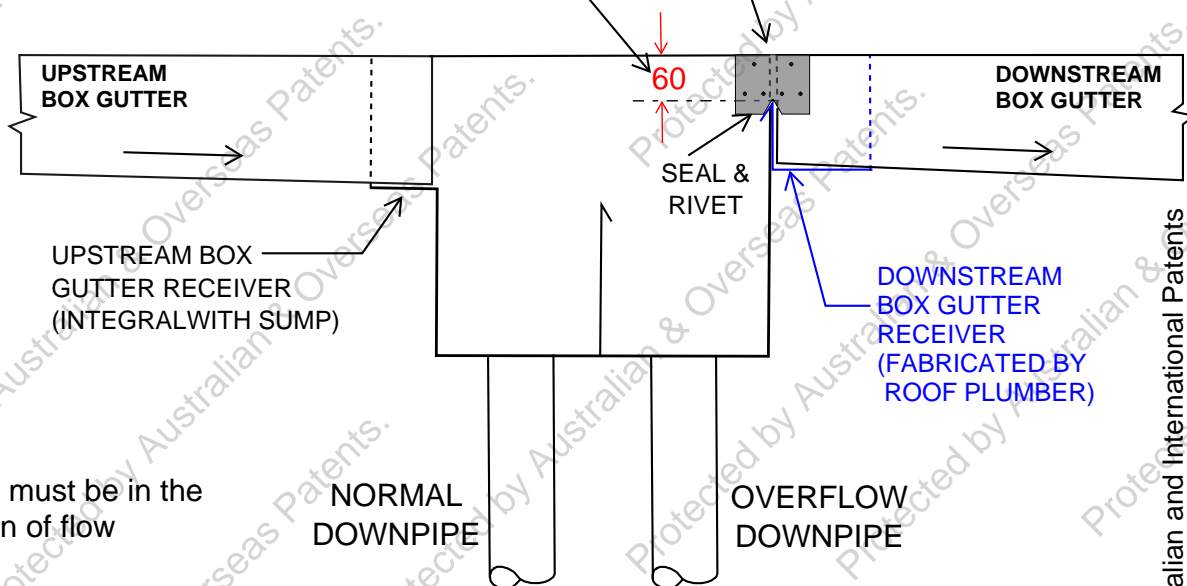

Note
 All laps must be in the direction of flow

SD0015A - Section X-X, SD0015
(Dam Buster Continuous Sump, as installed WITHOUT expansion joint)

Protected by various Australian and International Patents

DAM BUSTER[®]

Dam Buster Pty Ltd
 www.dambuster.com.au
 orders@dambuster.com.au

TITLE: Standard Details Sheets

DESIGNED	DRAWN
CHECKED	
SCALE NTS @A4	REVISION 4
DATE 01.02.2023	
JOB No.	SHEET No. SD015A

Note
Refer to the Sump detail for the Sump Deflector Cover ('SDC') to prevent nuisance flows from entering the overflow chamber

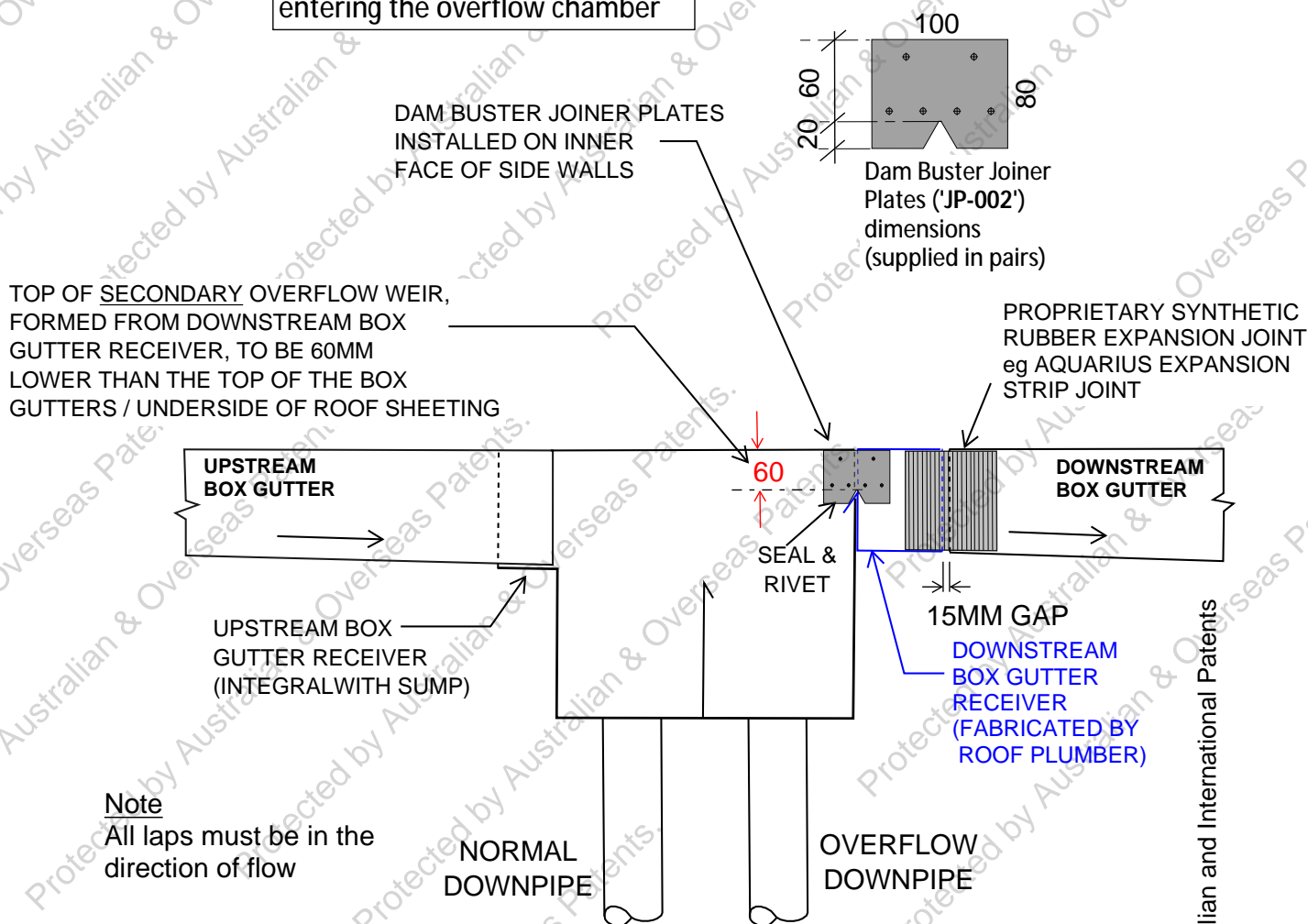

SD0015B - Section X-X, SD0015
(Dam Buster Continuous Sump, as installed WITH expansion joint)

Protected by various Australian and International Patents

DAM BUSTER[®]

Dam Buster Pty Ltd
www.dambuster.com.au
orders@dambuster.com.au

TITLE: Standard Details Sheets

DESIGNED	DRAWN
CHECKED	
SCALE NTS @A4	REVISION 4
DATE 01.02.2023	
JOB No.	SHEET No. SD015B

Dam Buster Sump Deflector Cover (Optional*)

SDC-WWW available for all sump sizes.

Sized to fit sump width. Sold separately.

* The Sump Deflector Cover prevents 'nuisance flows' entering the overflow chamber but may increase maintenance (cleaning) requirements.

NOTE
A full blockage indicator is recommended where possible to indicate blockage has occurred in both the normal downpipe and overflow downpipes

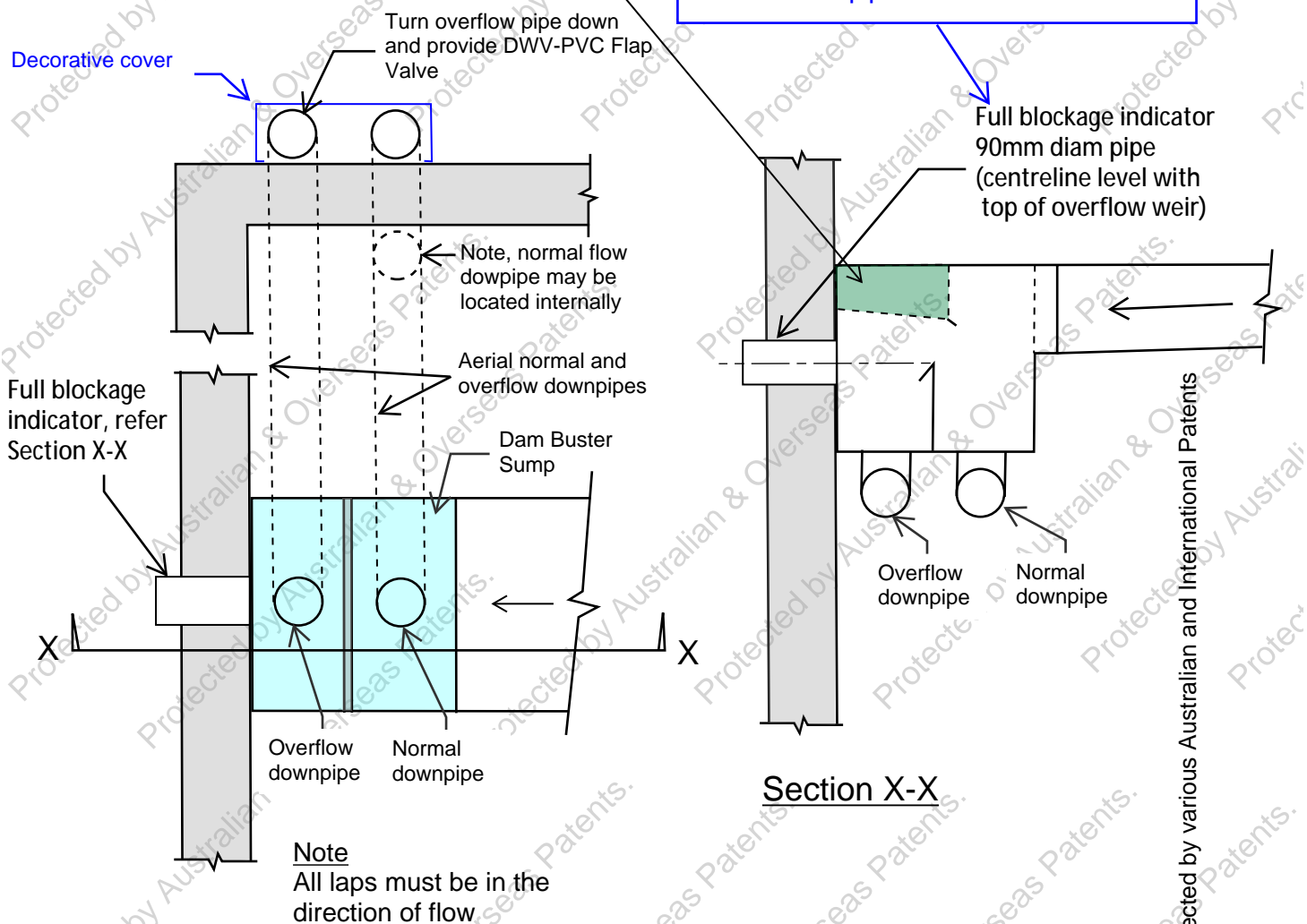

SD016 - Dam Buster Sump used in lieu of rainhead - Option A (NTS)

NOTES

1. Refer to the current Dam Buster manual for installation details
2. This arrangement may be required where a rainhead cannot be installed at the external wall (for example, the box gutter is located above a window or door opening)
3. Refer also SD017 for an alternative arrangement

DAM BUSTER®

Dam Buster Pty Ltd
www.dambuster.com.au
orders@dambuster.com.au

TITLE: Standard Details Sheets

DESIGNED	DRAWN
CHECKED	
SCALE NTS @A4	REVISION 4
DATE 01.02.2023	
JOB No.	SHEET No. SD016

Dam Buster Sump Deflector Cover (Optional*)

SDC-WWW available for all sump sizes.

Sized to fit sump width. Sold separately.

* The Sump Deflector Cover prevents 'nuisance flows' entering the overflow chamber but may increase maintenance (cleaning) requirements.

NOTE

A full blockage indicator is recommended where possible to indicate blockage has occurred in both the normal downpipe and overflow downpipes

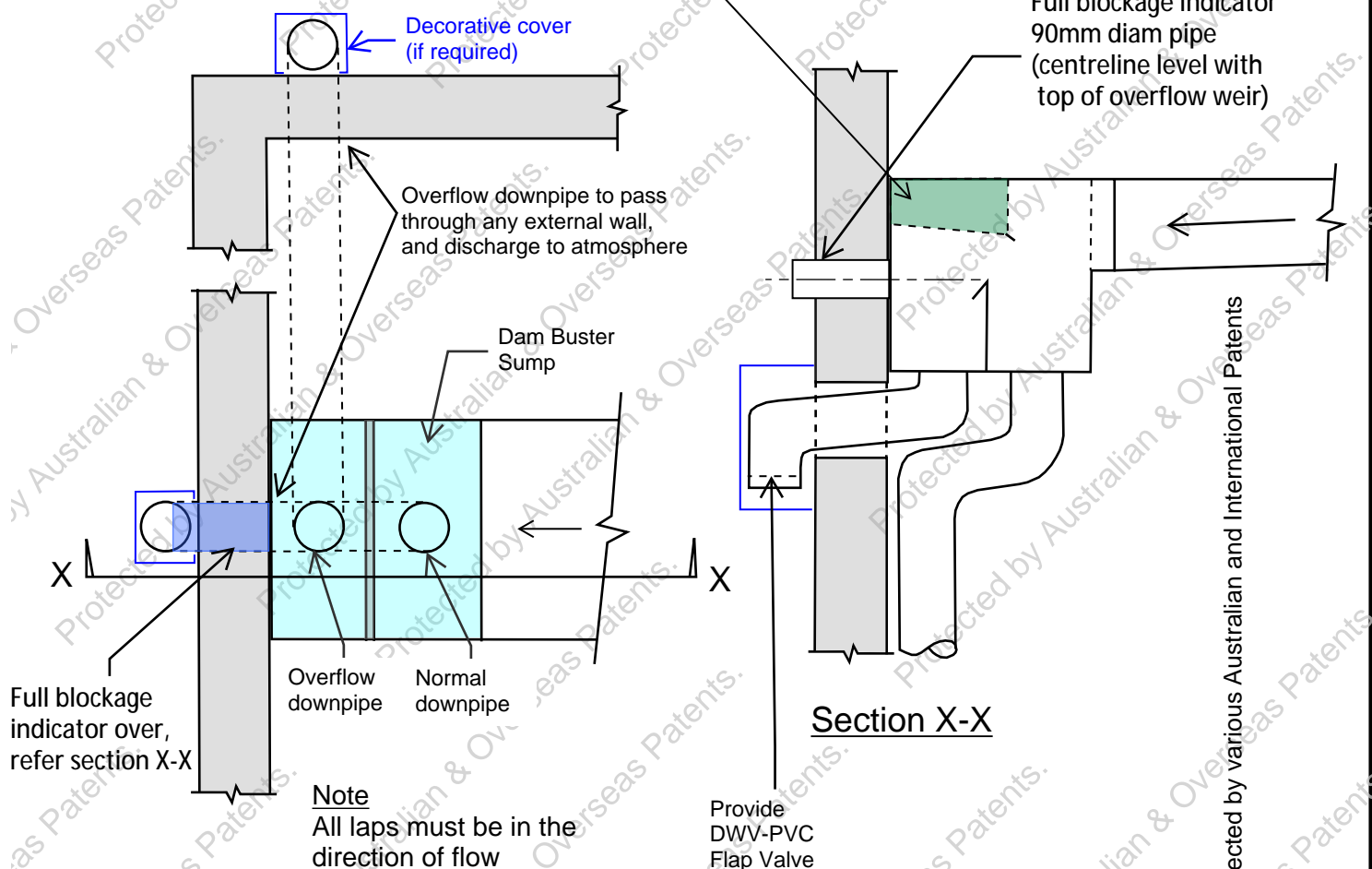

SD017 - Dam Buster Sump used in lieu of rainhead - Option B (NTS)

NOTES

1. Refer to the current Dam Buster manual for installation details
2. This arrangement may be required where a rainhead cannot be installed at the external wall (for example, the box gutter is located above a window or door opening)
3. Refer also SD0016 for an alternative arrangement

DAM BUSTER®

Dam Buster Pty Ltd
www.dambuster.com.au
orders@dambuster.com.au

TITLE: Standard Details Sheets

DESIGNED	DRAWN
CHECKED	
SCALE NTS @A4	REVISION 4
DATE 01.02.2023	
JOB No.	SHEET No. SD017

Protected by various Australian and International Patents

Note
Elbows have in-built tapers to ensure that lapping is in the correct direction of flow.

Step

Upstream box gutter

Contraction range

Note
All laps must be in the direction of flow

LH as drawn

Sliding components allow for contraction of upstream box gutter width i.e., smaller upstream box gutter width transitioning to larger downstream box gutter width.

Downstream box gutter

Dam Buster Elbow (LH)

Dam Buster Elbow

Dam Buster Elbow size	Upstream Contraction range (mm)	Downstream box gutter width	Nominal Step
ELB-200-L	200 (fixed) mm	200 mm	50 mm
ELB-300-L	200 to 300 mm	300 mm	60 mm
ELB-400-L	300 to 400 mm	400 mm	70 mm
ELB-500-L	400 to 500 mm	500 mm	70 mm
ELB-600-L	400 to 600 mm	600 mm	70 mm

SD018 - Dam Buster Elbow (NTS)

NOTES

1. Refer to the current Dam Buster manual for installation details

DAM BUSTER[®]

Dam Buster Pty Ltd
www.dambuster.com.au
orders@dambuster.com.au

TITLE: Standard Details Sheets

DESIGNED	DRAWN
CHECKED	
SCALE NTS @A4	REVISION 4
DATE 01.02.2023	
JOB No.	SHEET No. SD018

Protected by various Australian and International Patents

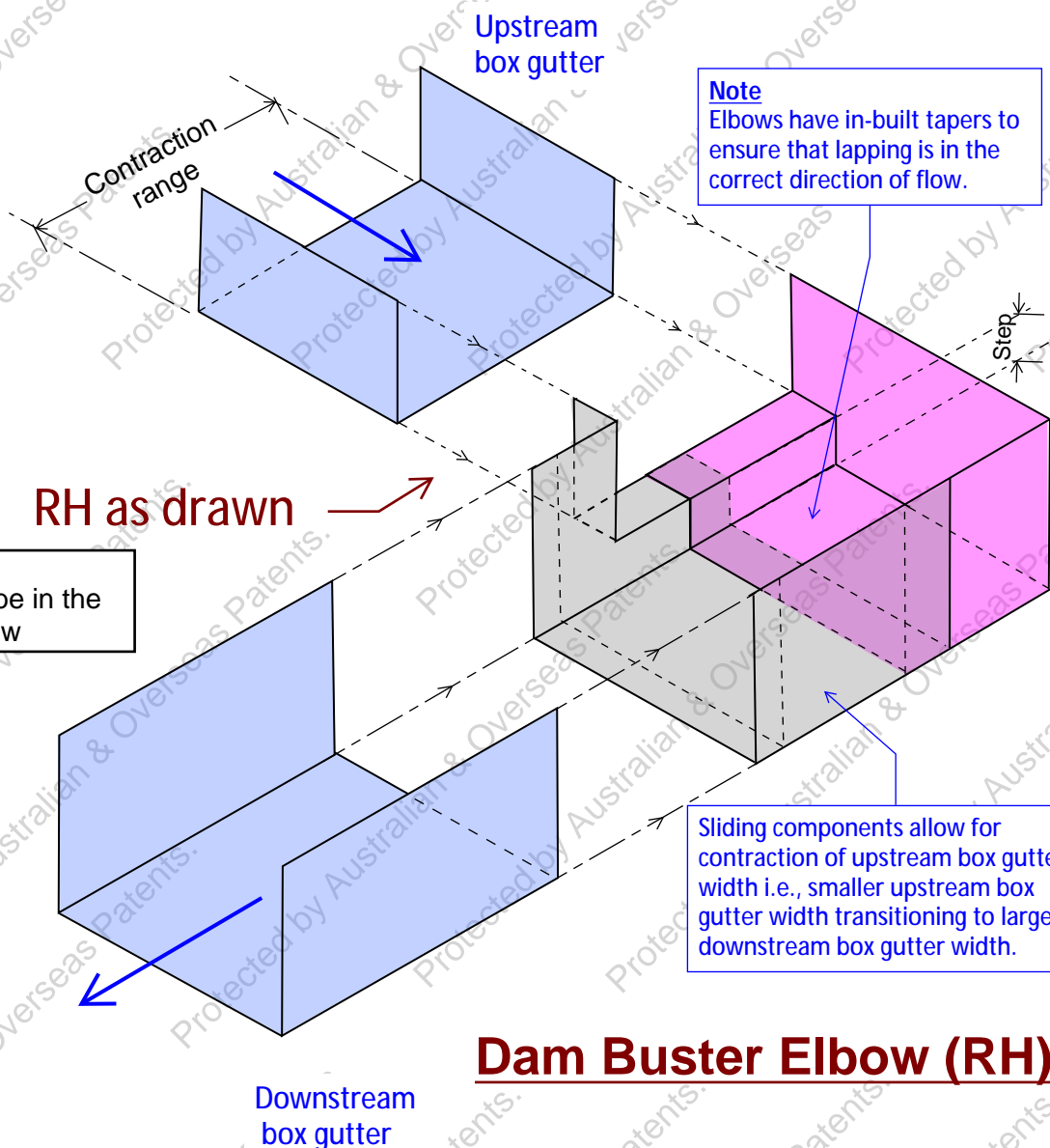

Dam Buster Elbow (RH)

Dam Buster Elbow

Dam Buster Elbow size	Upstream Contraction range (mm)	Downstream box gutter width	Nominal Step
ELB-200-R	200 (fixed) mm	200 mm	50 mm
ELB-300-R	200 to 300 mm	300 mm	60 mm
ELB-400-R	300 to 400 mm	400 mm	70 mm
ELB-500-R	400 to 500 mm	500 mm	70 mm
ELB-600-R	400 to 600 mm	600 mm	70 mm

SD018 - Dam Buster Elbow (NTS)

NOTES

1. Refer to the current Dam Buster manual for installation details

DAM BUSTER[®]

Dam Buster Pty Ltd
www.dambuster.com.au
orders@dambuster.com.au

TITLE: Standard Details Sheets

DESIGNED	DRAWN
CHECKED	
SCALE NTS @A4	REVISION 4
DATE 01.02.2023	
JOB No.	SHEET No.
	SD018A

Protected by various Australian and International Patents

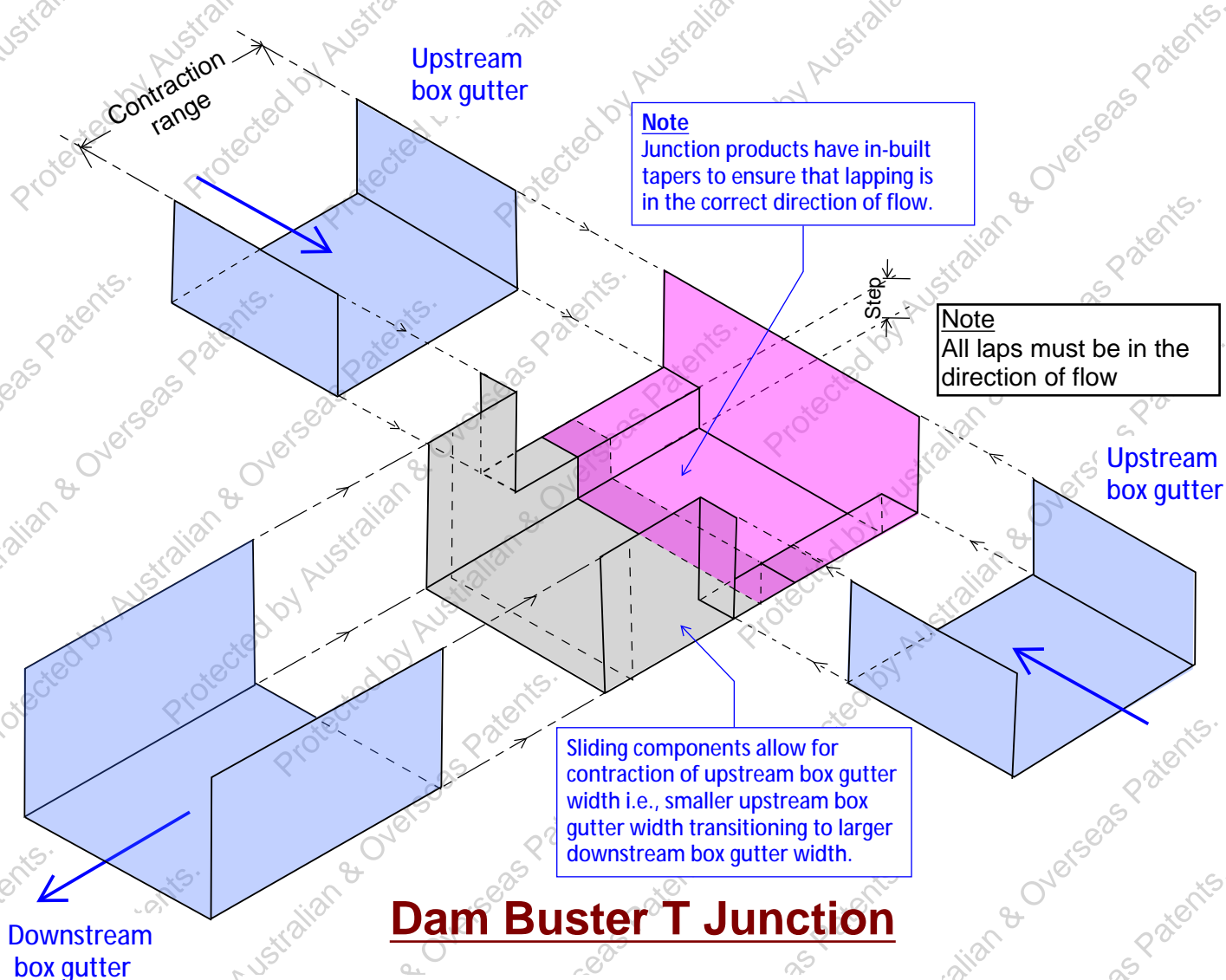

Dam Buster T Junction

Dam Buster T Junction

Junction size	Upstream Contraction range	Downstream width	Nominal Step
TJN-200	200 (fixed) mm	200 mm	50 mm
TJN-300	200 to 300 mm	300 mm	60 mm
TJN-400	300 to 400 mm	400 mm	70 mm

SD019 - Dam Buster T Junction (NTS)

NOTES

1. Refer to the current Dam Buster manual for installation details

DAM BUSTER[®]

Dam Buster Pty Ltd
www.dambuster.com.au
orders@dambuster.com.au

TITLE: Standard Details Sheets

DESIGNED	DRAWN
CHECKED	
SCALE NTS @A4	REVISION
DATE 12.04.2023	
JOB No.	SHEET No.
	SD019

NOTE
 All Dam Buster® products are protected by various Australian and International Patents. Refer to www.dambuster.com.au to order, and for installation details.

Note
 Junction products have in-built tapers to ensure that lapping is in the correct direction of flow.

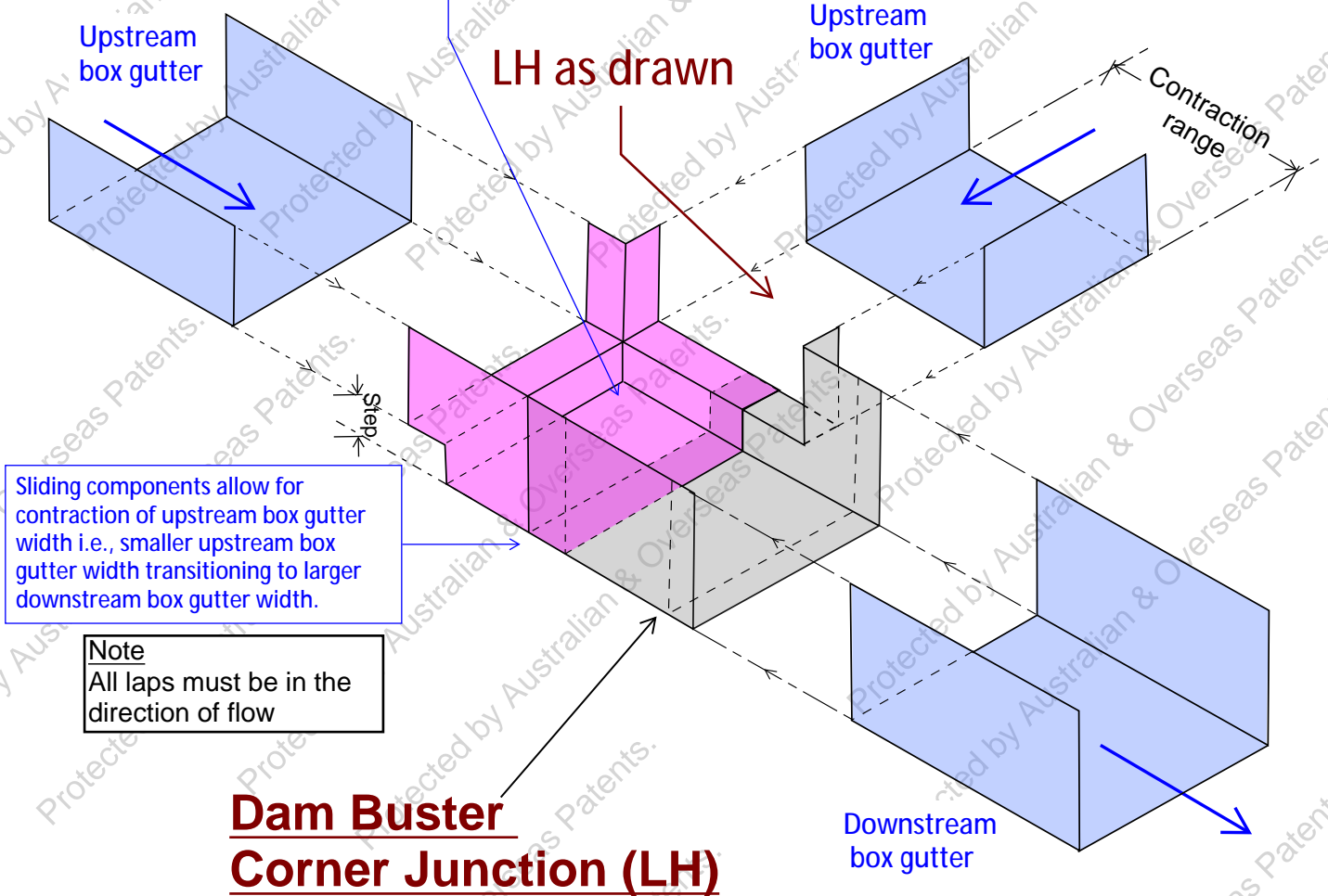

Dam Buster Corner Junction (LH)

Dam Buster Corner Junction

Junction size	Upstream Contraction range	Downstream width	Nominal Step
CJN-200-L	200 (fixed) mm	200 mm	50 mm
CJN-300-L	200 to 300 mm	300 mm	60 mm
CJN-400-L	300 to 400 mm	400 mm	70 mm

SD020 - Dam Buster Corner Junction (NTS)

- NOTES**
 1. Refer to the current Dam Buster manual for installation details

<p style="font-size: small; margin-top: 10px;">Dam Buster Pty Ltd www.dambuster.com.au orders@dambuster.com.au</p>	CLIENT:	DESIGNED	DRAWN	
	PROJECT:	CHECKED		
	ADDRESS:	SCALE NTS @A4	REVISION	
	TITLE: Standard Details Sheets	DATE 12.04.2023		
		JOB No.	SHEET No. SD020	

NOTE

All Dam Buster® products are protected by various Australian and International Patents. Refer to www.dambuster.com.au to order, and for installation details.

Note

Junction products have in-built tapers to ensure that lapping is in the correct direction of flow.

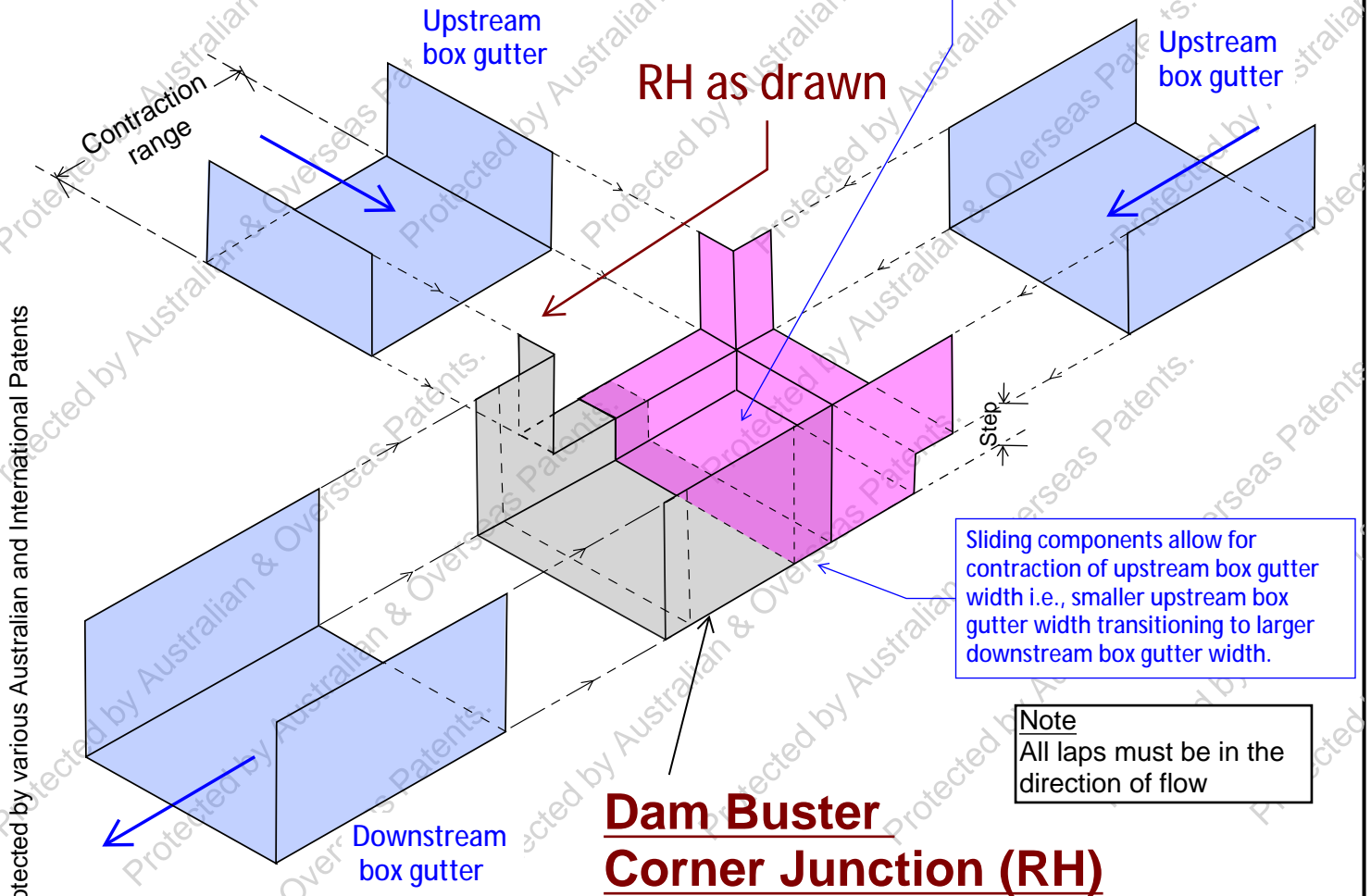

**Dam Buster
Corner Junction (RH)**

Dam Buster Corner Junction

Junction size	Upstream Contraction range	Downstream width	Nominal Step
CJN-200-R	200 (fixed) mm	200 mm	50 mm
CJN-300-R	200 to 300 mm	300 mm	60 mm
CJN-400-R	300 to 400 mm	400 mm	70 mm

SD020 - Dam Buster Corner Junction (NTS)

NOTES

1. Refer to the current Dam Buster manual for installation details

DAM BUSTER®

Dam Buster Pty Ltd
www.dambuster.com.au
orders@dambuster.com.au

CLIENT:	DESIGNED	DRAWN
PROJECT:	CHECKED	
ADDRESS:	SCALE NTS @A4	REVISION
	DATE 12.04.2023	
TITLE: Standard Details Sheets	JOB No.	SHEET No.
		SD020A



Appendix D

Dam Buster Product Data Sheets

Product Data Sheet

Rainhead R-www & R-www-F



Standard sizes to suit 200mm, 300mm, 400mm, 500mm and 600mm wide box gutters. Refer to the table below for available Non-Standard sizes.

-F refers to the Flat Back version of the rainhead (i.e no box gutter receiver)

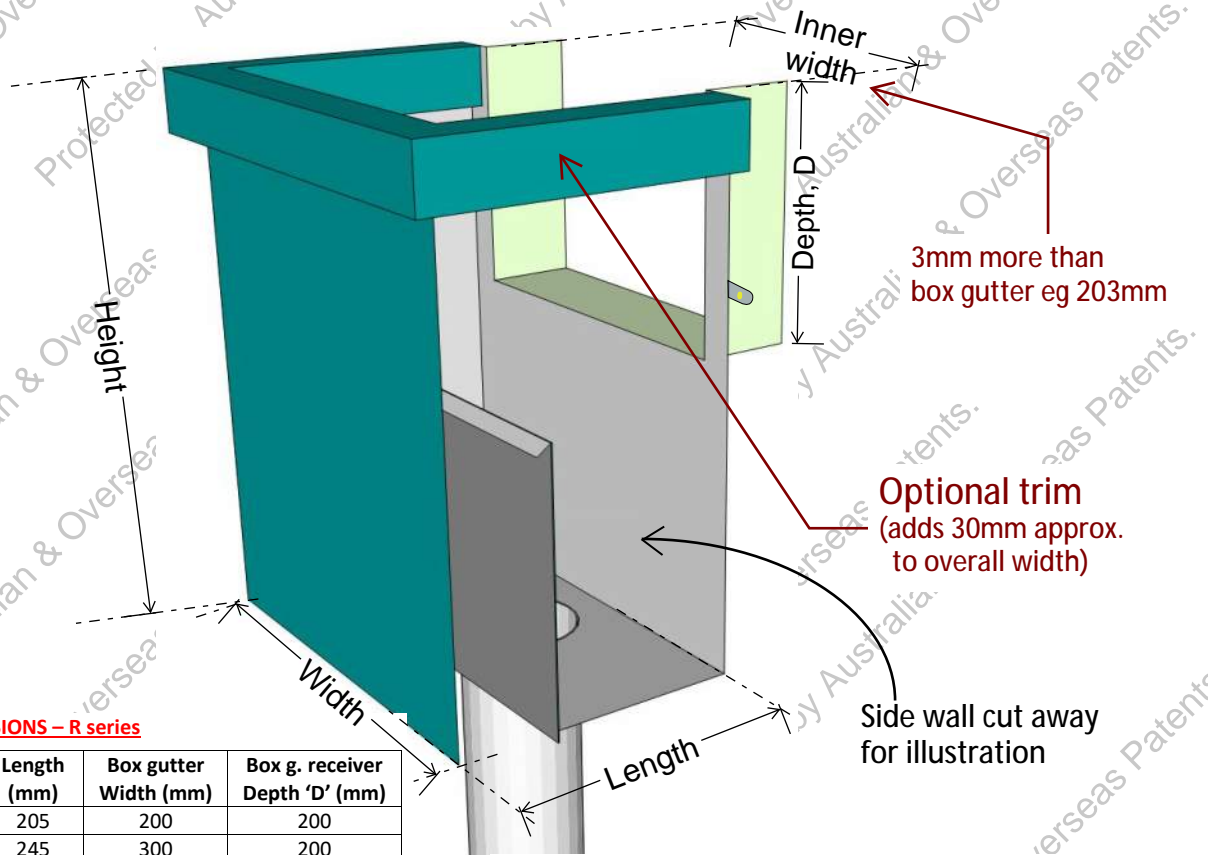

STANDARD RAINHEAD DIMENSIONS – R series

Rainhead size	Width (mm)	Height (mm)	Length (mm)	Box gutter Width (mm)	Box g. receiver Depth 'D' (mm)
R-200	265	350	205	200	200
R-300	365	450	245	300	200
R-400	465	600	325	400	250
R-500	565	650	325	500	275
R-600	665	700	325	600	300

MINI* RAINHEAD DIMENSIONS MR-200

Rainhead size	Width (mm)	Height (mm)	Length (mm)	Box gutter Width (mm)	Box g. receiver Depth 'D' (mm)
MR-200	265	275	205	200	150

* The rainhead height (including the box gutter receiver) is reduced

WIDENED* RAINHEAD DIMENSIONS WR-200+ & WR-300+

Rainhead size	Width (mm)	Height (mm)	Length (mm)	Box gutter Width (mm)	Box g. receiver Depth 'D' (mm)
WR-200+	365	350	205	200	200
WR-300+	465	450	245	300	200

* The rainhead (excluding the box gutter receiver) is widened in the direction perpendicular to the box gutter.

MAXI* RAINHEAD DIMENSIONS R-300-MX

Rainhead size	Width (mm)	Height (mm)	Length (mm)	Box gutter Width (mm)	Box g. receiver Depth 'D' (mm)
R-300-MX	365	450	300	300	200

* The rainhead is lengthened (only) in the direction parallel to the box gutter.

STRETCHED* RAINHEAD DIMENSIONS R-200-xxx & R-300-xxx series

Rainhead size	Width (mm)	Height (mm)	Length (mm)	Box gutter Width (mm)	Box g. receiver Depth 'D' (mm)
R-200-300	365	350	205	300	200
R-300-350	415	450	245	350	200
R-300-380	445	450	245	380	200
R-300-400	465	450	245	400	200
R-300-450	515	450	245	450	200
R-300-500	565	450	245	500	200
R-300-600	615	450	245	500	200

* The rainhead (including the box gutter receiver) is 'stretched' in the direction perpendicular to the box gutter.



CERTIFIED PRODUCT
(RECTANGULAR RAINHEAD
OVERFLOW PERFORMANCE)



HARDWARE AND BUILDING
PRODUCT DESIGN

GOOD DESIGN
AWARD
WINNER

DAM BUSTER
RAIN HEAD

DAM BUSTER®

Product Data Sheet

Curved Rainhead CR-www & CR-www-F



Standard sizes to suit 200mm, 300mm, 400mm 500mm & 600mm wide box gutters.

-F refers to the Flat Back version of the rainhead (i.e no box gutter receiver)

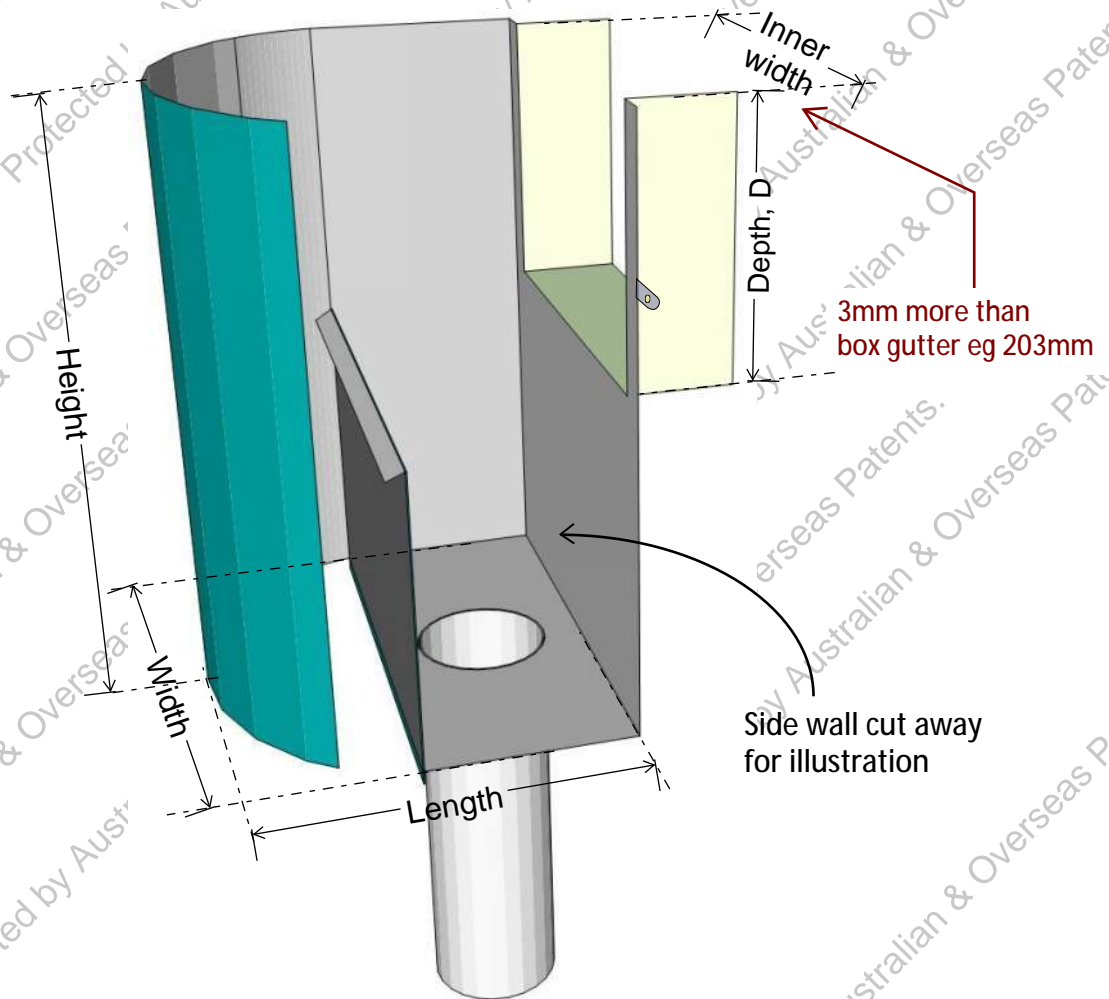

CURVED RAINHEAD DIMENSIONS – CR series

Rainhead size	Width (mm)	Height (mm)	Length (mm)	Box gutter Width (mm)	Box g. receiver Depth 'D' (mm)
CR-200	265	350	240	200	200
CR-300	365	450	290	300	200
CR-400	465	600	375	400	250
CR-500	565	650	375	500	275
CR-600	665	700	375	600	300

MAXI* CURVED RAINHEAD DIMENSIONS CR-300-MX

Rainhead size	Width (mm)	Height (mm)	Length (mm)	Box gutter Width (mm)	Box g. receiver Depth 'D' (mm)
CR-300-MX	365	450	345	300	200

* The rainhead is lengthened (only) in the direction parallel to the box gutter

MINI* CURVED RAINHEAD DIMENSIONS MCR-200

Rainhead size	Width (mm)	Height (mm)	Length (mm)	Box gutter Width (mm)	Box g. receiver Depth 'D' (mm)
MCR-200	265	275	240	200	150

* The rainhead height (including the box gutter receiver) is reduced



Product Data Sheet 'T' Side Outlets TSO-www

Standard sizes to suit any box gutter width between 200mm to 600mm.
Must only be used in combination with a Dam Buster Rainhead

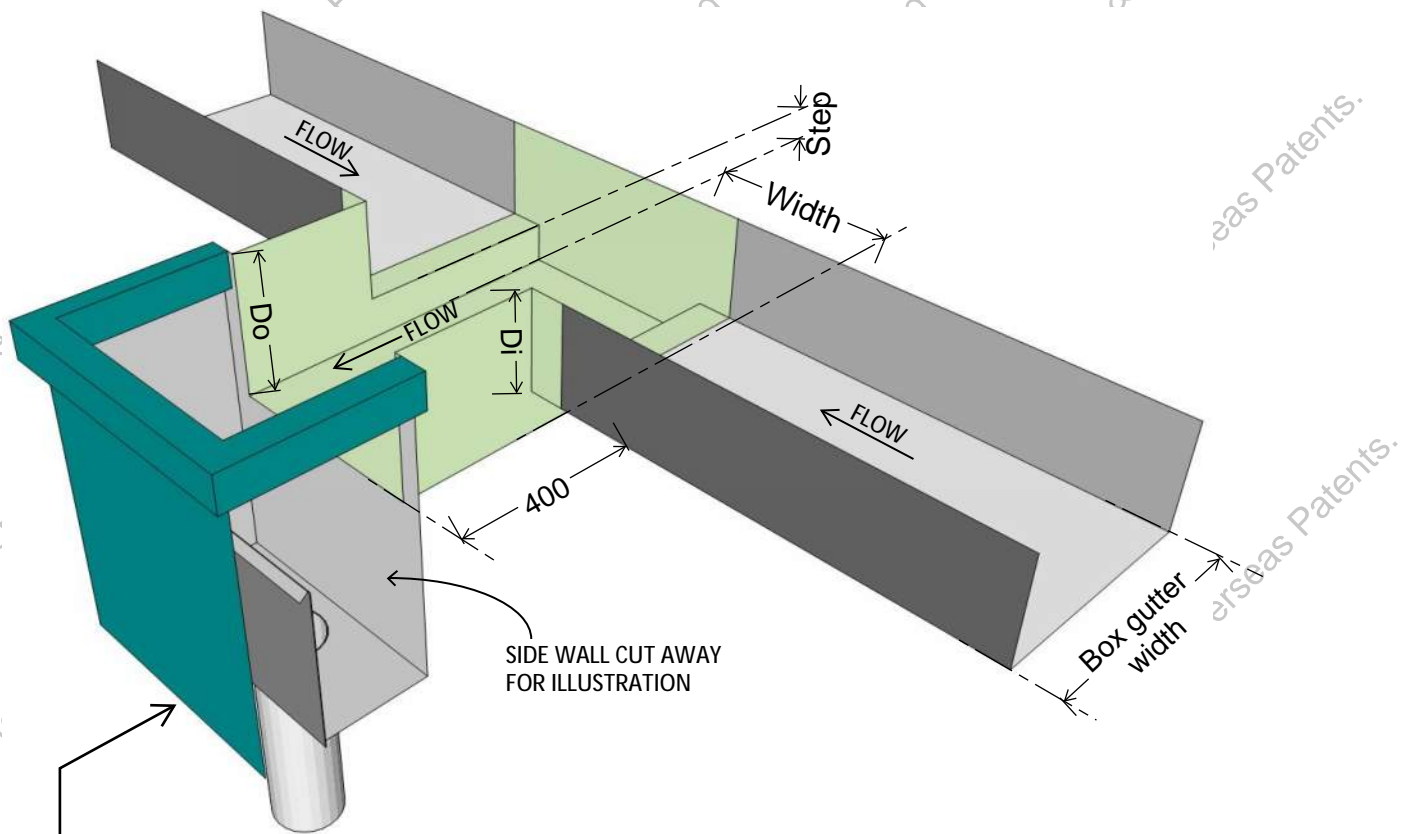

Refer to Rainhead
PDS for details

NOTE - The T Side Outlet may also be used in combination with a Dam Buster Sump - refer to the Standard Details drawings

'T' Side Outlet dimensions

Side Outlet size	Rainhead size	Width (mm)	Nominal Step (mm)	INLET Depth, Di (mm)	OUTLET Depth, Do (mm)	Box gutter width range (mm)
TSO-200	R-200 or CR-200	200	50	150	200	200 to 350
TSO-300	R-300 or CR-300	300	60	140	200	300 to 450
TSO-400	R-400 or CR-400	400	70	180	250	400 to 600



Product Data Sheet

'End' Side Outlets ESO-www-L

Standard sizes to suit any box gutter width between 200mm to 600mm.
Must only be used in combination with a Dam Buster Rainhead

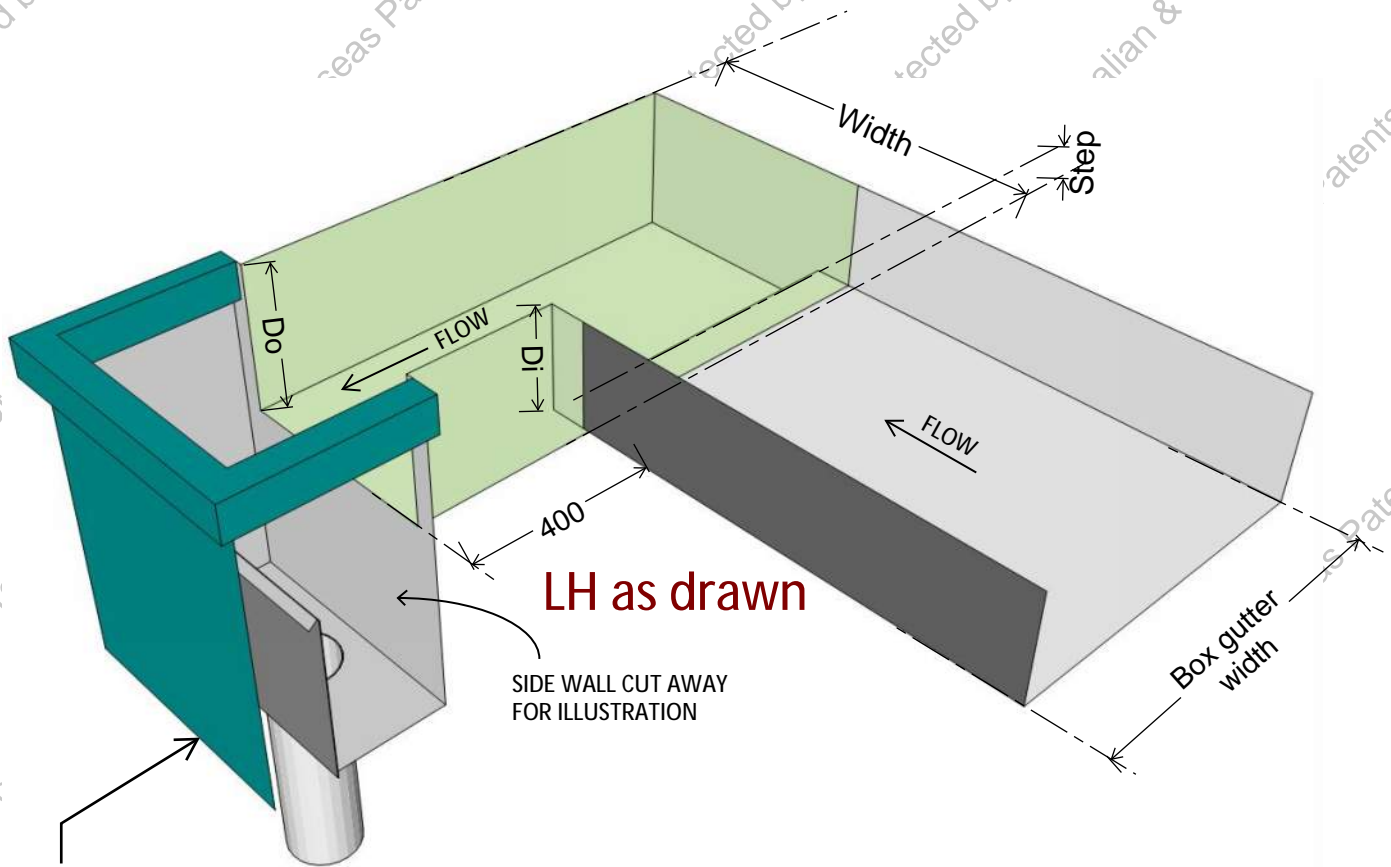

Refer to Rainhead PDS for details

NOTE - The End Side Outlet may also be used in combination with a Dam Buster Sump - refer to the Standard Details drawings

'End' Side Outlet dimensions

Side Outlet size	Rainhead size	Width (mm)	Nominal Step (mm)	INLET Depth, Di (mm)	OUTLET Depth, Do (mm)	Box gutter width range (mm)
ESO-200-L	R-200 or CR-200	200	50	150	200	200 to 350
ESO-300-L	R-300 or CR-300	300	60	140	200	300 to 450
ESO-400-L	R-400 or CR-400	400	70	180	250	400 to 600



Product Data Sheet

'End' Side Outlets ESO-www-R

Standard sizes to suit any box gutter width between 200mm to 600mm.
Must only be used in combination with a Dam Buster Rainhead

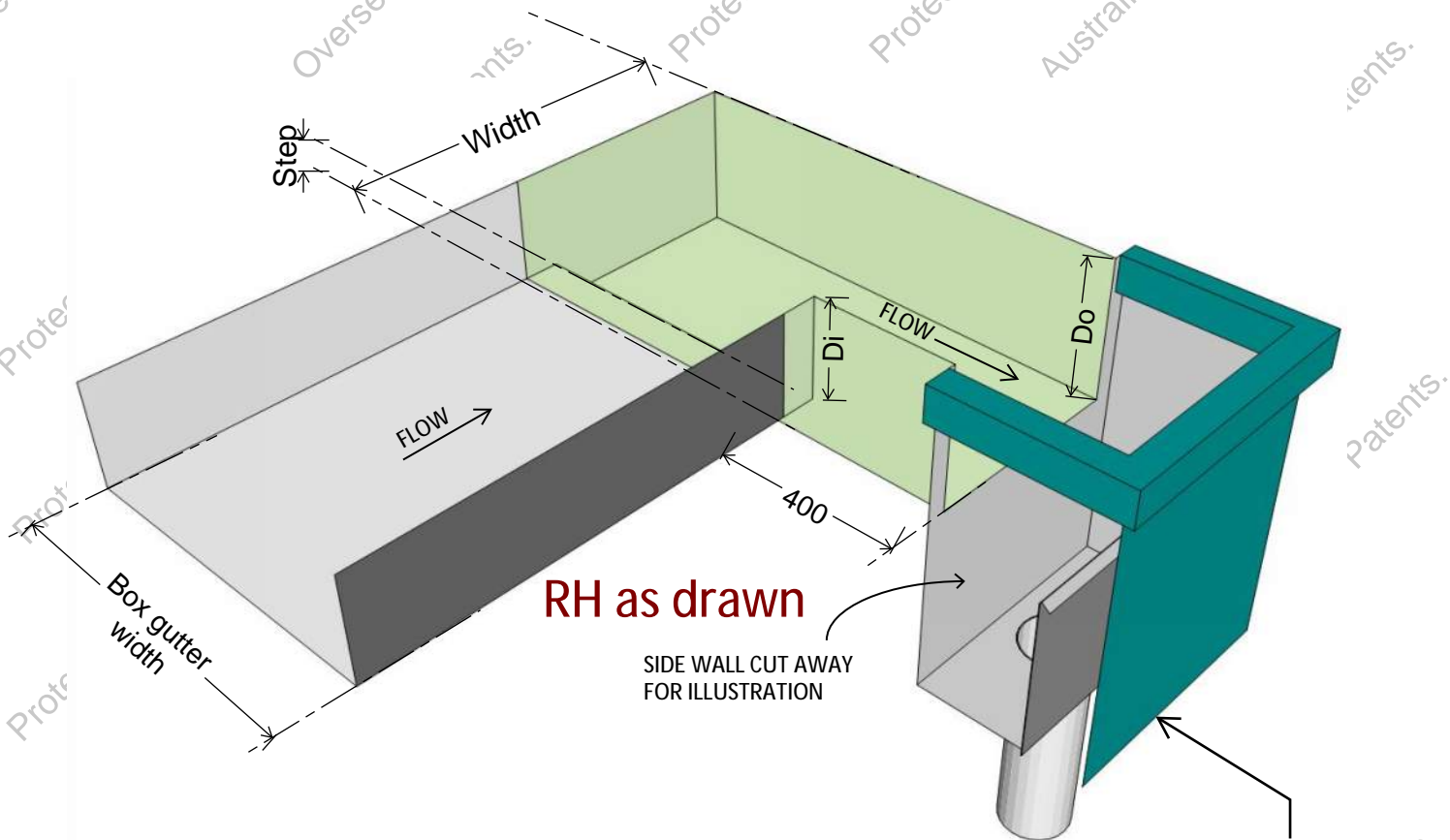

NOTE - The End Side Outlet may also be used in combination with a Dam Buster Sump - refer to the Standard Details drawings

'End' Side Outlet dimensions

Side Outlet size	Rainhead size	Width (mm)	Nominal Step (mm)	INLET Depth, Di (mm)	OUTLET Depth, Do (mm)	Box gutter width range (mm)
ESO-200- R	R-200 or CR-200	200	50	150	200	200 to 350
ESO-300- R	R-300 or CR-300	300	60	140	200	300 to 450
ESO-400- R	R-400 or CR-400	400	70	180	250	400 to 600



Product Data Sheet

'Corner' Side Outlets CSO-www-L

Standard sizes to suit any box gutter width between 200mm to 600mm.
Must only be used in combination with a Dam Buster Rainhead

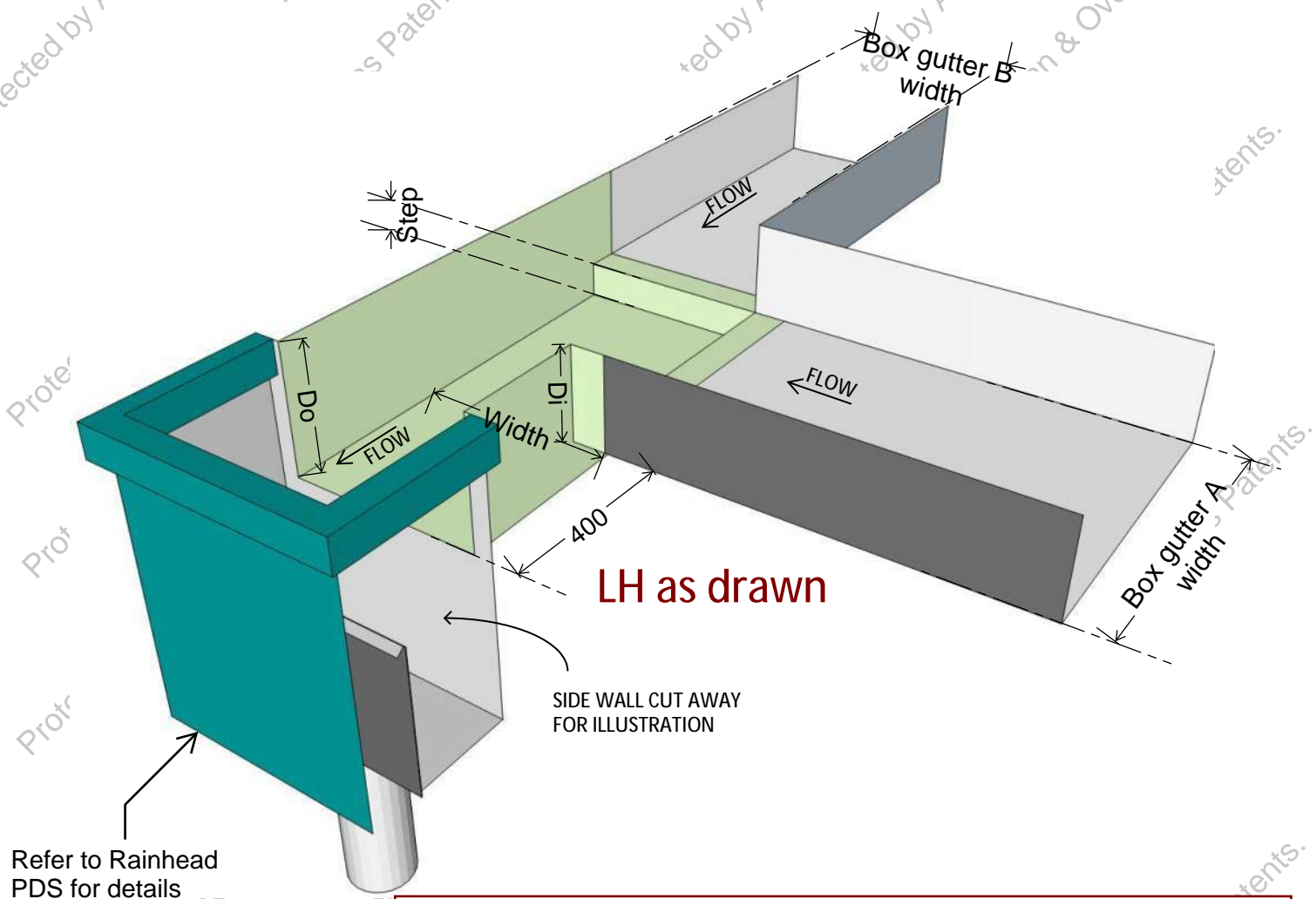

NOTE - The Corner Side Outlet may also be used in combination with a Dam Buster Sump - refer to the Standard Details drawings

'Corner' Side Outlet dimensions

Side Outlet Size	Rainhead size	Width (mm)	Nominal Step (mm)	INLET Depth, Di (mm)	OUTLET Depth, Do (mm)	Box gutter A width range (mm)	Box gutter B width (mm)
CSO-200-L	R-200 or CR-200	200	50	150	200	200 to 350	200
CSO-300-L	R-300 or CR-300	300	60	140	200	300 to 450	300
CSO-400-L	R-400 or CR-400	400	70	180	250	400 to 600	400



Product Data Sheet

'Corner' Side Outlets CSO-www-R

Standard sizes to suit any box gutter width between 200mm to 600mm.
Must only be used in combination with a Dam Buster Rainhead

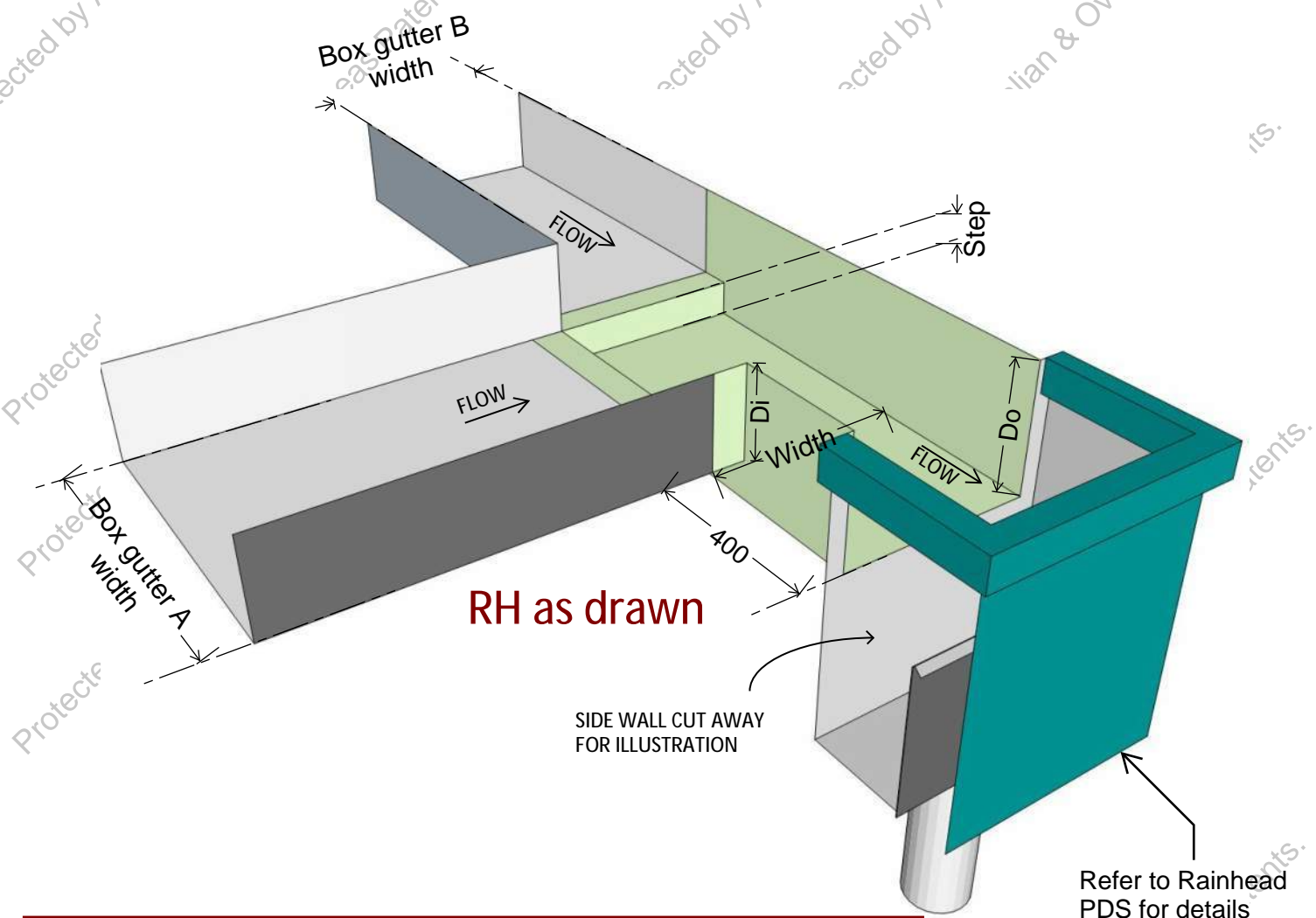

NOTE - The Corner Side Outlet may also be used in combination with a Dam Buster Sump - refer to the Standard Details drawings

'Corner' Side Outlet dimensions

Side Outlet Size	Rainhead size	Width (mm)	Nominal Step (mm)	INLET Depth, Di (mm)	OUTLET Depth, Do (mm)	Box gutter A width range (mm)	Box gutter B width (mm)
CSO-200- R	R-200 or CR-200	200	50	150	200	200 to 350	200
CSO-300- R	R-300 or CR-300	300	60	140	200	300 to 450	300
CSO-400- R	R-400 or CR-400	400	70	180	250	400 to 600	400



Product Data Sheet

'Cruciform' Side Outlets XSO-www

Standard sizes to suit any box gutter width between 200mm to 600mm.
Must only be used in combination with a Dam Buster Rainhead

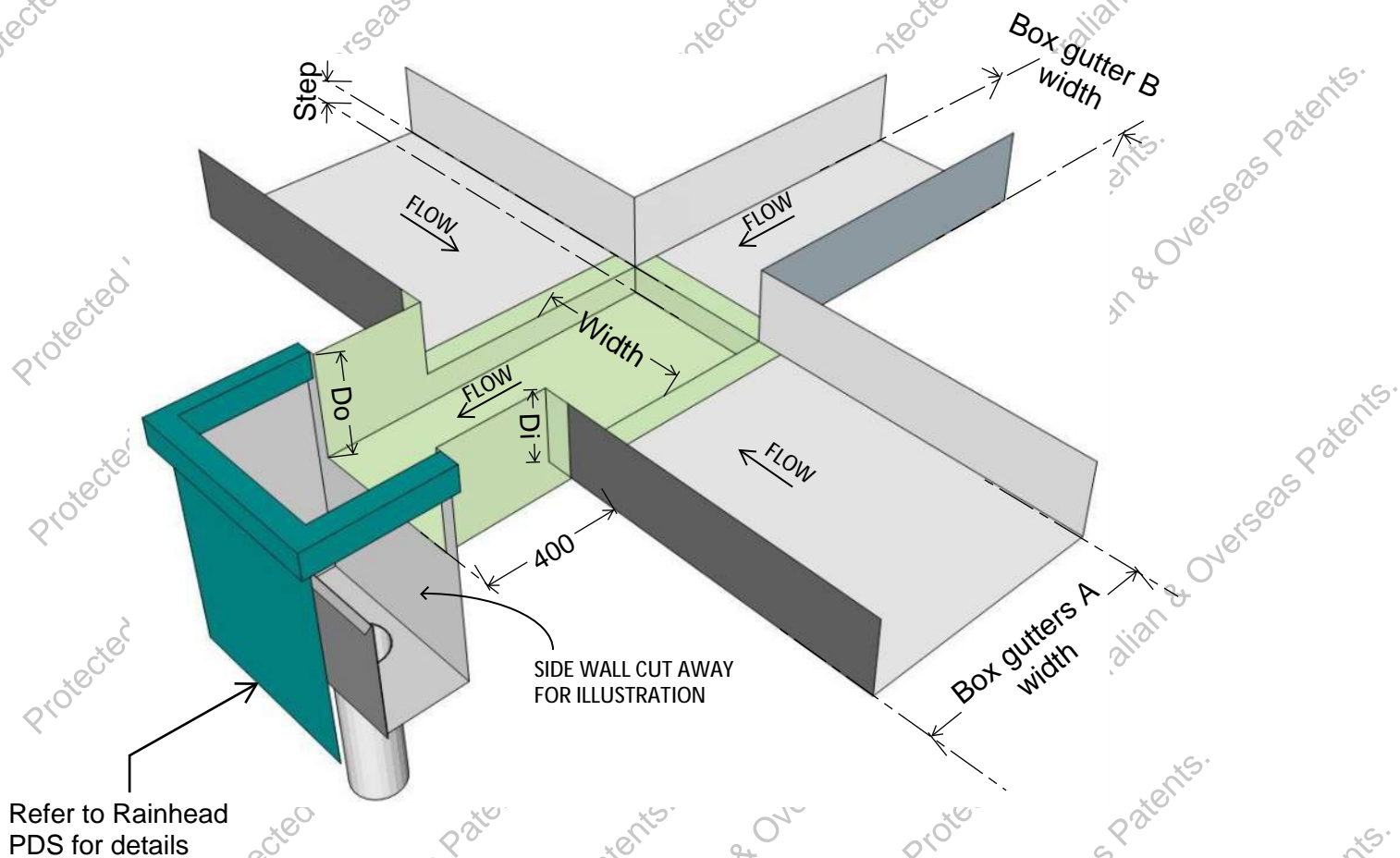

NOTE - The Cruciform Side Outlet may also be used in combination with a Dam Buster Sump - refer to the Standard Details drawings

'Cruciform' Side Outlet dimensions

Side Outlet Size	Rainhead size	Width (mm)	Nominal Step (mm)	INLET Depth, Di (mm)	OUTLET Depth, Do (mm)	Box gutters A width range (mm)	Box gutters B width range (mm)
XSO-200	R-200 or CR-200	200	50	150	200	200 to 350	200
XSO-300	R-300 or CR-300	300	60	140	200	300 to 450	300
XSO-400	R-400 or CR-400	400	70	180	250	400 to 600	400



DAM BUSTER®

Product Data Sheet

Sumps SU-www-ddd

Standard sizes to suit box gutter widths of 200mm, 300mm, 400mm, 500mm & 600mm

FULL BLOCKAGE OVERFLOW INDICATOR
(SUPPLIED & INSTALLED BY THE ROOF PLUMBER) TO BE LOCATED AS SHOWN OR ON EITHER SIDE OF THE OVERFLOW CHAMBER (REFER ALSO TO THE STANDARD SUMP DETAIL, DRAWING SD013).

NOTE - SUMP DEFLECTOR COVER

REFER TO THE STANDARD SUMP DRAWINGS FOR DETAILS OF THE (OPTIONAL) SUMP DEFLECTOR COVER, WHICH IS INSTALLED ABOVE THE OVERFLOW COMPARTMENT AND WHICH REDIRECTS 'NUISANCE' FLOWS INTO THE SUMP COMPARTMENT CONTAINING THE NORMAL / PRIMARY DOWNPIPE.

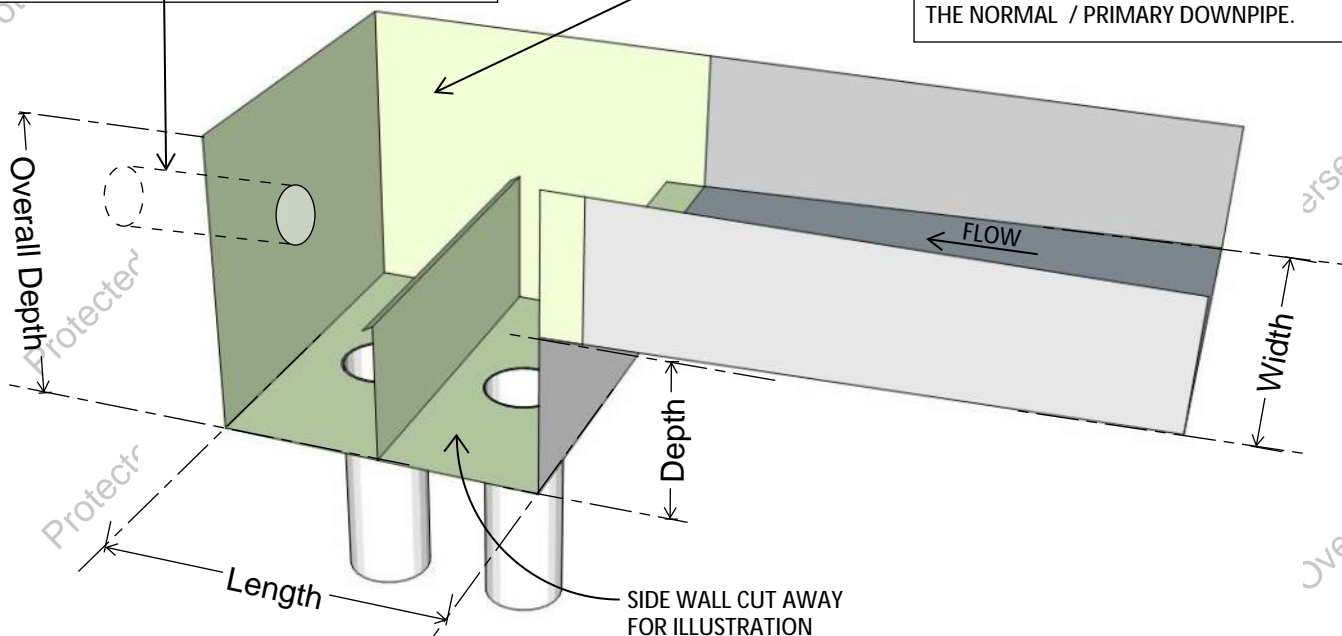

Sump dimensions

Sump size	Width (mm)	Depth (mm)	Length (mm)	Overall Depth (mm)
SU-200-100	205	100	400	300
SU-200-150	205	150	400	350
SU-300-75	305	75	400	280
SU-300-125	305	125	400	330
SU-300-200	305	200	400	405
SU-400-150	405	150	400	400
SU-400-200	405	200	400	450
SU-500-150	505	150	400	300
SU-500-200	505	200	400	400
SU-600-150	605	150	400	300
SU-600-200	605	200	400	400



DAM BUSTER®

Product Data Sheet

Continuous Sumps SU-www-ddd*

* Ordered as a Dam Buster Sump

Standard sizes to suit box gutter widths of 200mm, 300mm, 400mm, 500mm & 600mm

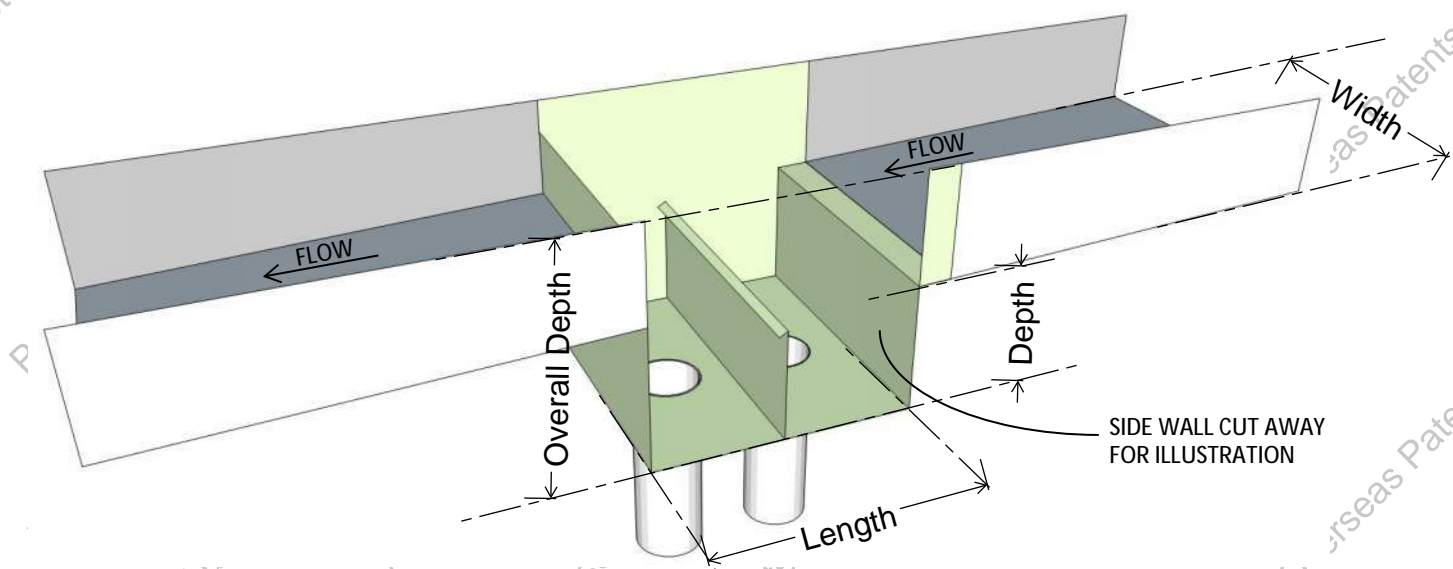

Continuous Sump dimensions

Sump size	Width (mm)	Depth (mm)	Length (mm)	Overall Depth (mm)
SU-200-100	205	100	400	300
SU-200-150	205	150	400	350
SU-300-75	305	75	400	280
SU-300-125	305	125	400	330
SU-300-200	305	200	400	405
SU-400-150	405	150	400	400
SU-400-200	405	200	400	450
SU-500-150	505	150	400	300
SU-500-200	505	200	400	400
SU-600-150	605	150	400	300
SU-600-200	605	200	400	400



DAM BUSTER®

Product Data Sheet

Elbows - ELB-www-L

Standard sizes to suit any box gutter width between 200mm to 600mm.

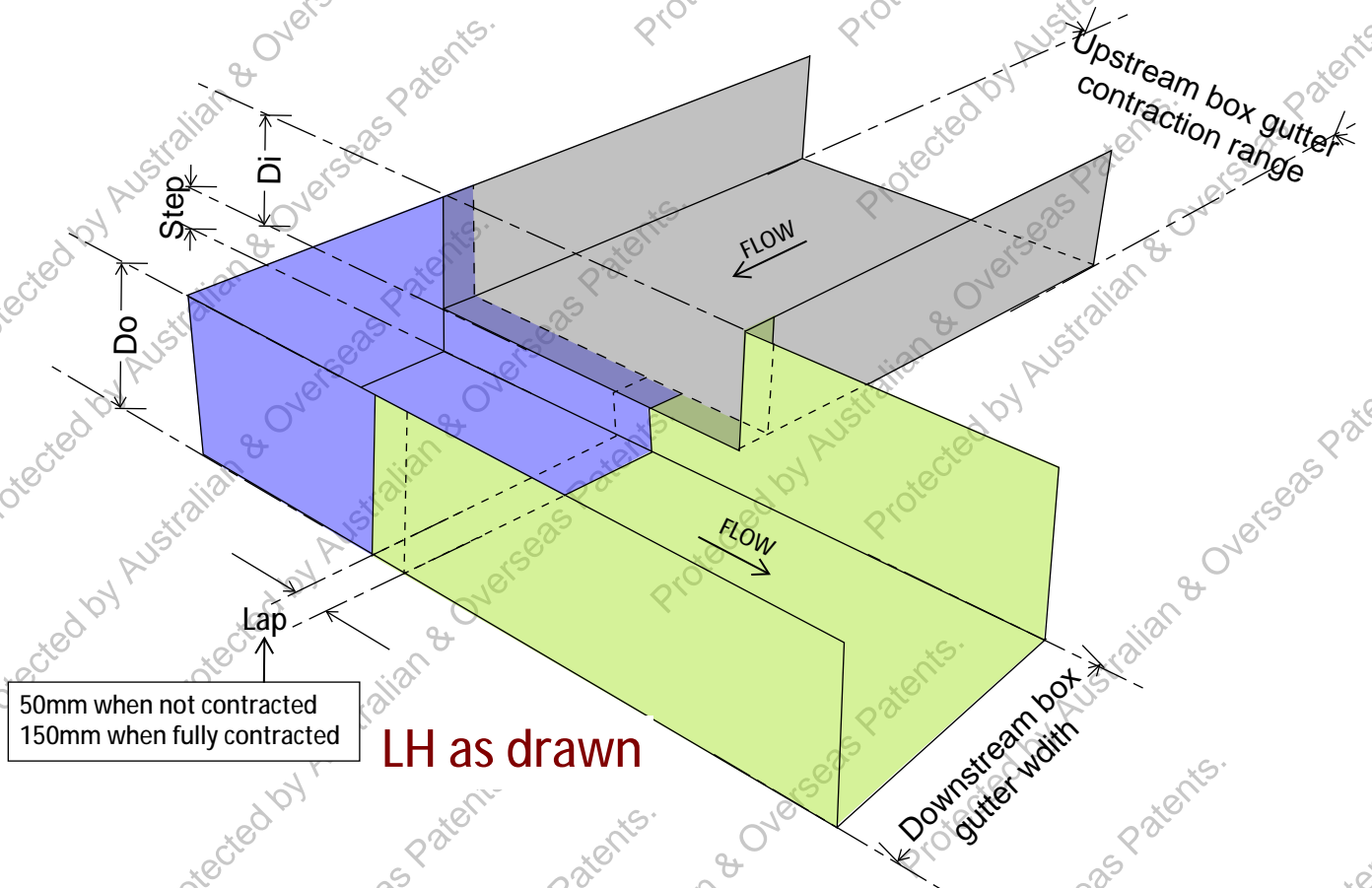

ELBOW dimensions

Elbow size	Upstream Contraction range (mm)	Downstream width (mm)	Nominal Step (mm)	INLET Depth, Di (mm)	OUTLET Depth, Do (mm)
ELB-200- L	200 (fixed)	197	50	180	230
ELB-300- L	200 to 300	297	60	215	275
ELB-400- L	300 to 400	397	70	230	300
ELB-500- L	300 to 500	497	70	230	300
ELB-600- L	400 to 600	597	70	230	300



Product Data Sheet

Elbows - ELB-www-R

Standard sizes to suit any box gutter width between 200mm to 600mm.

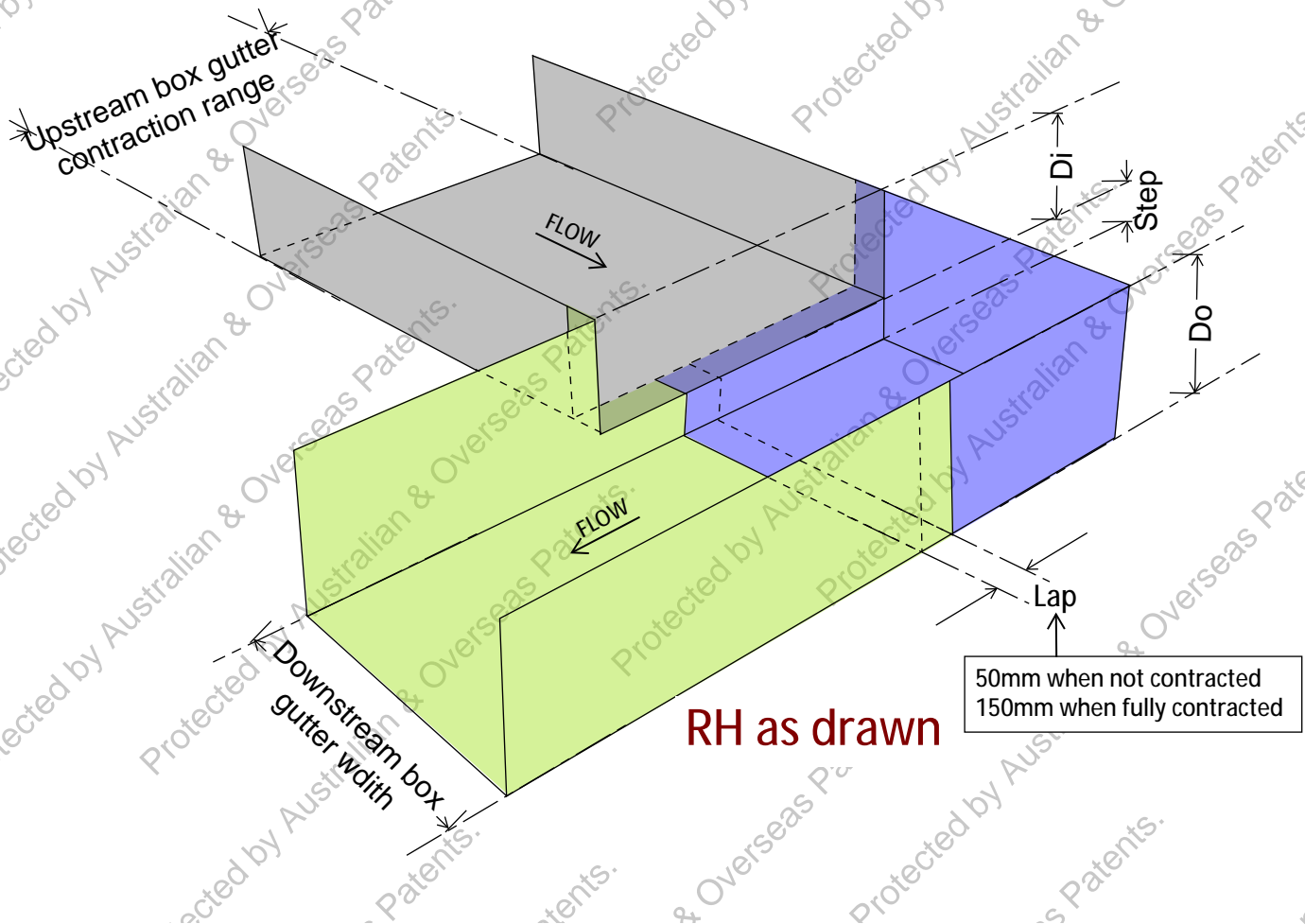

ELBOW dimensions

Elbow size	Upstream Contraction range (mm)	Downstream width (mm)	Nominal Step (mm)	INLET Depth, Di (mm)	OUTLET Depth, Do (mm)
ELB-200- R	200 (fixed)	197	50	180	230
ELB-300- R	200 to 300	297	60	215	275
ELB-400- R	300 to 400	397	70	230	300
ELB-500- R	300 to 500	497	70	230	300
ELB-600- R	400 to 600	597	70	230	300



DAM BUSTER[®]

Product Data Sheet T Junction TJN-www

Standard sizes to suit any box gutter width between 200mm to 400mm.

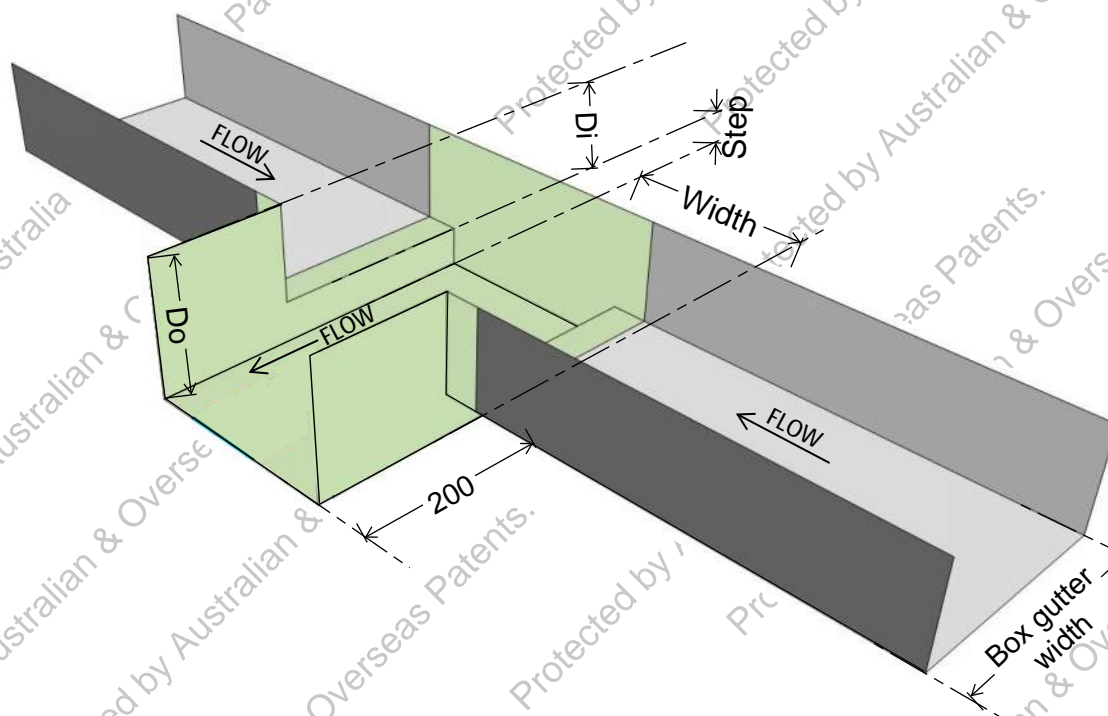

T JUNCTION dimensions

T Junction size	Upstream Contraction range (mm)	Downstream width (mm)	Nominal Step (mm)	INLET Depth, Di (mm)	OUTLET Depth, Do (mm)
TJN-200	200 (fixed)	197	50	180	230
TJN-300	200 to 300	297	60	215	275
TJN-400	300 to 400	397	70	230	300



Product Data Sheet

Corner Junction CJN-www-L

Standard sizes to suit any box gutter width between 200mm to 400mm.

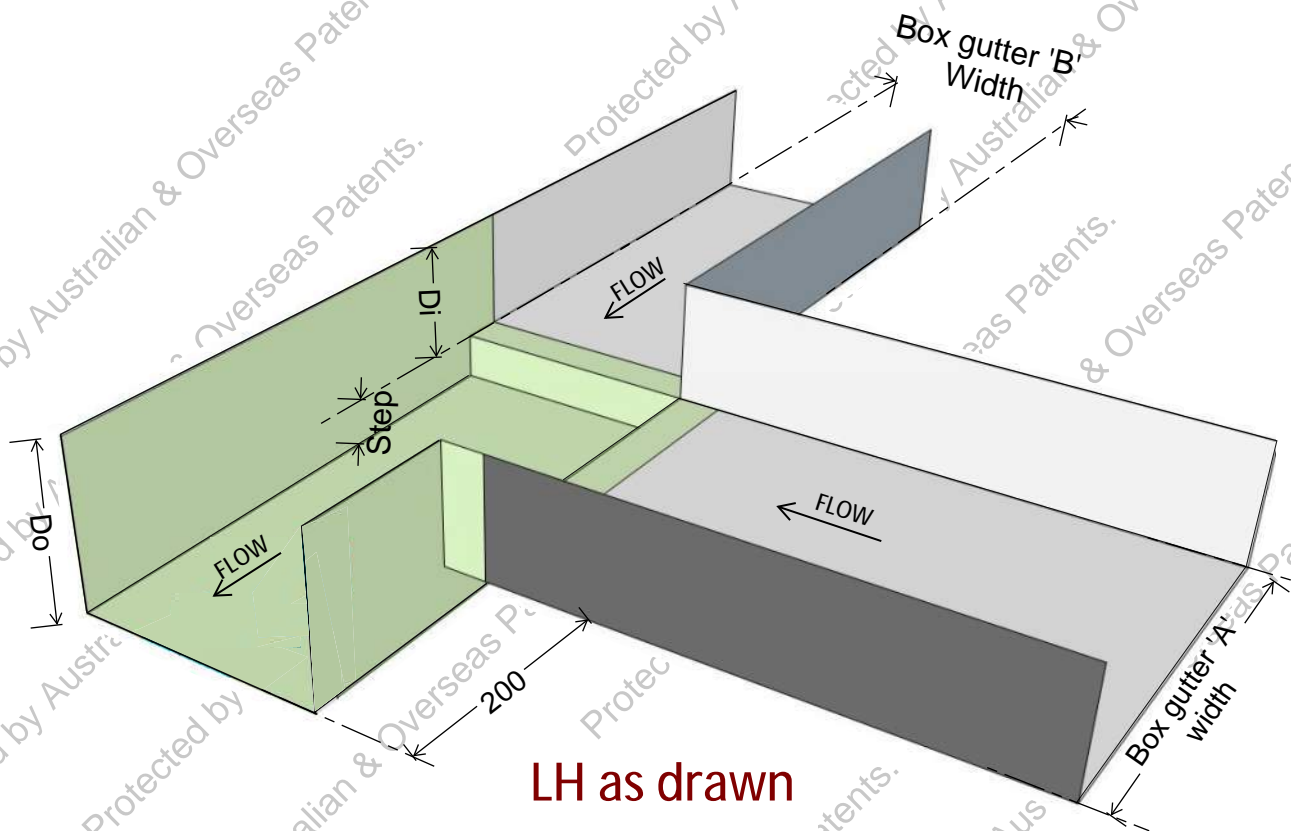

CORNER JUNCTION dimensions

Corner Junction Size	Downstream width (mm)	Nominal Step (mm)	INLET Depth, Di (mm)	OUTLET Depth, Do (mm)	Box gutter A contraction range (mm)	Box gutter B width (mm)
CJN-200-L	197	50	180	230	200	200
CJN-300-L	297	60	215	275	200 to 300	300
CJN-400-L	397	70	230	300	300 to 400	400



Product Data Sheet

Corner Junction CJN-www-R

Standard sizes to suit any box gutter width between 200mm to 400mm.

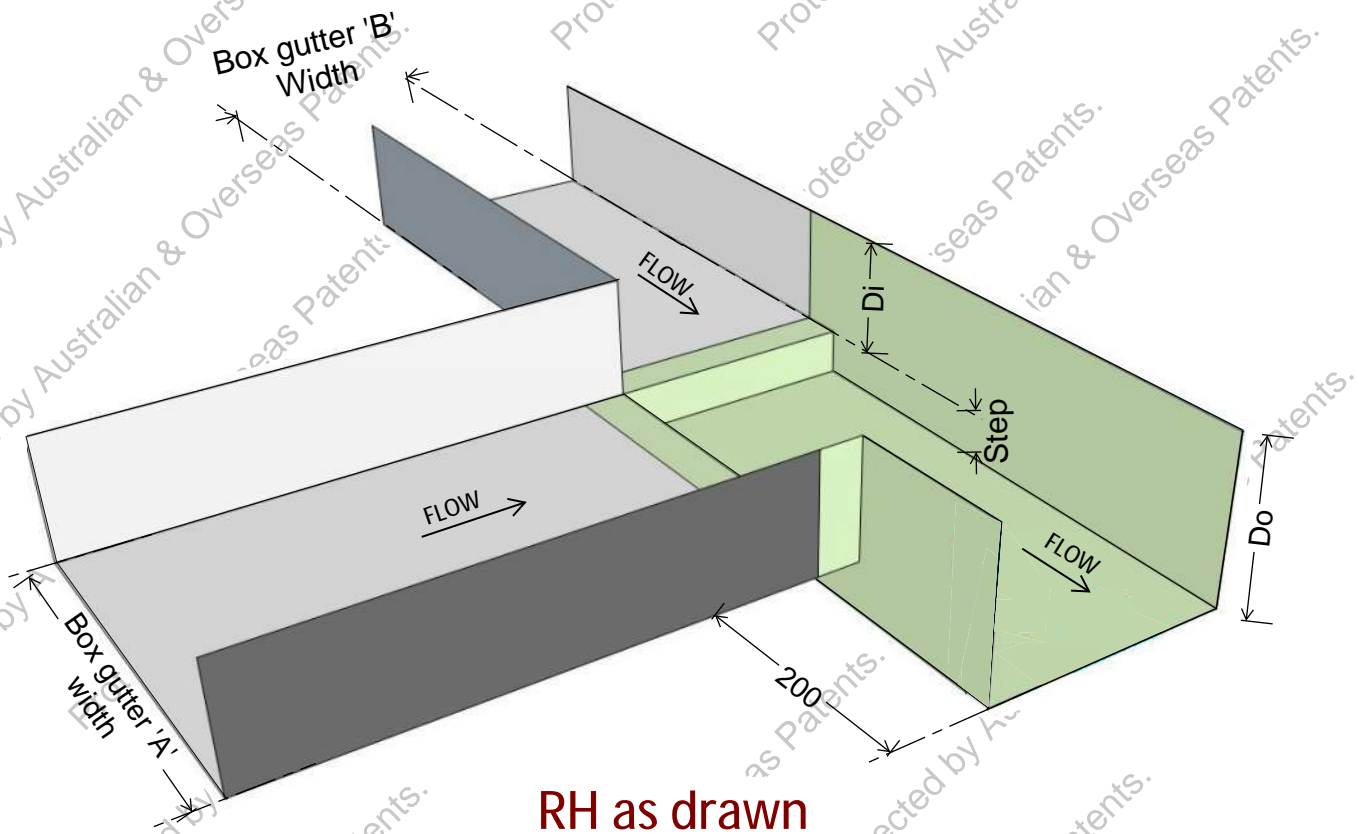

CORNER JUNCTION dimensions

Corner Junction Size	Downstream width (mm)	Nominal Step (mm)	INLET Depth, Di (mm)	OUTLET Depth, Do (mm)	Box gutter A contraction range (mm)	Box gutter B width (mm)
CJN-200-R	197	50	180	230	200	200
CJN-300-R	297	60	215	275	200 to 300	300
CJN-400-R	397	70	230	300	300 to 400	400

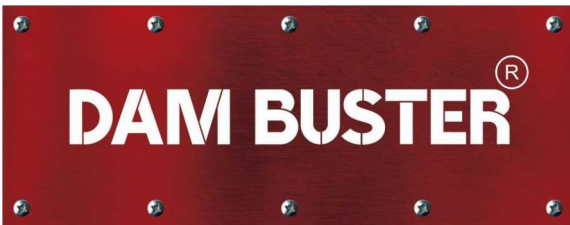

Product Data Sheet

Flashing Kits

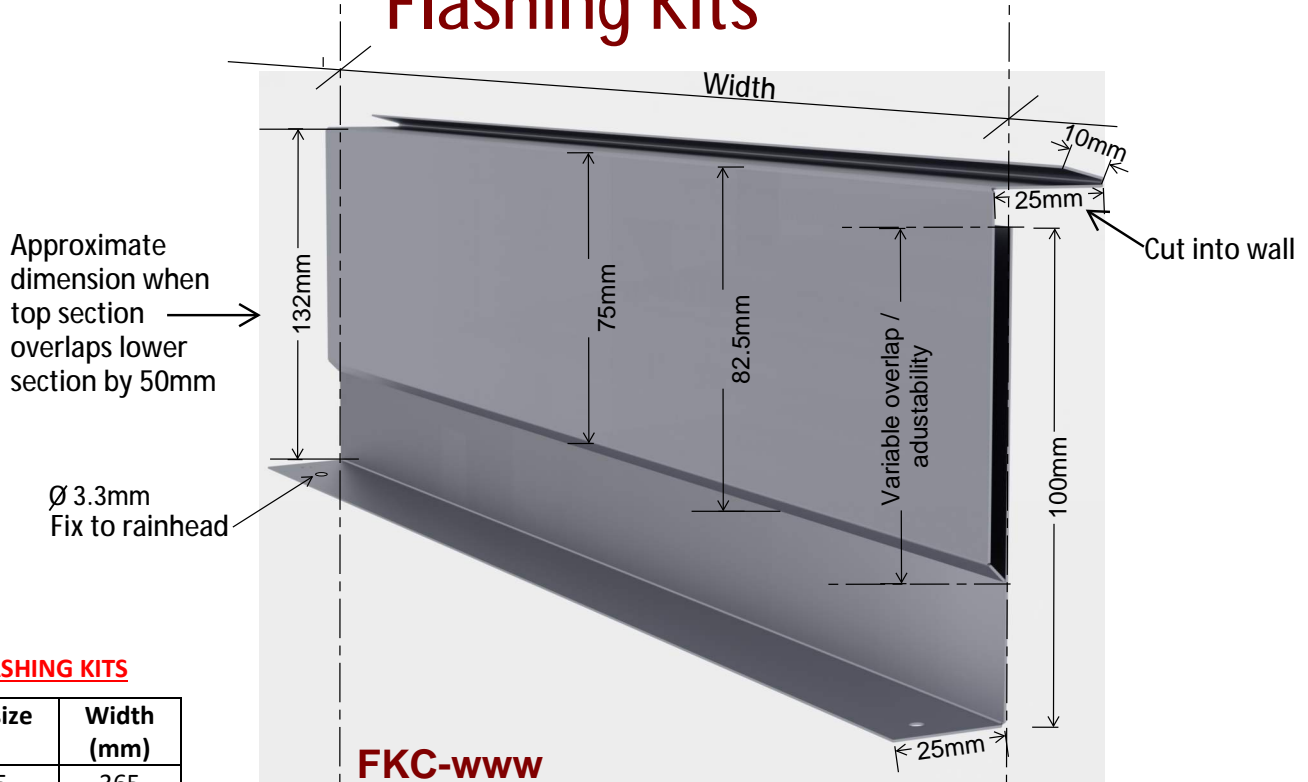

CHASED FLASHING KITS

Flashing size	Width (mm)
FKC-365	365
FKC-465	465
FKC-665	665

FKC-ww
Flashing Kit - Chased flashing

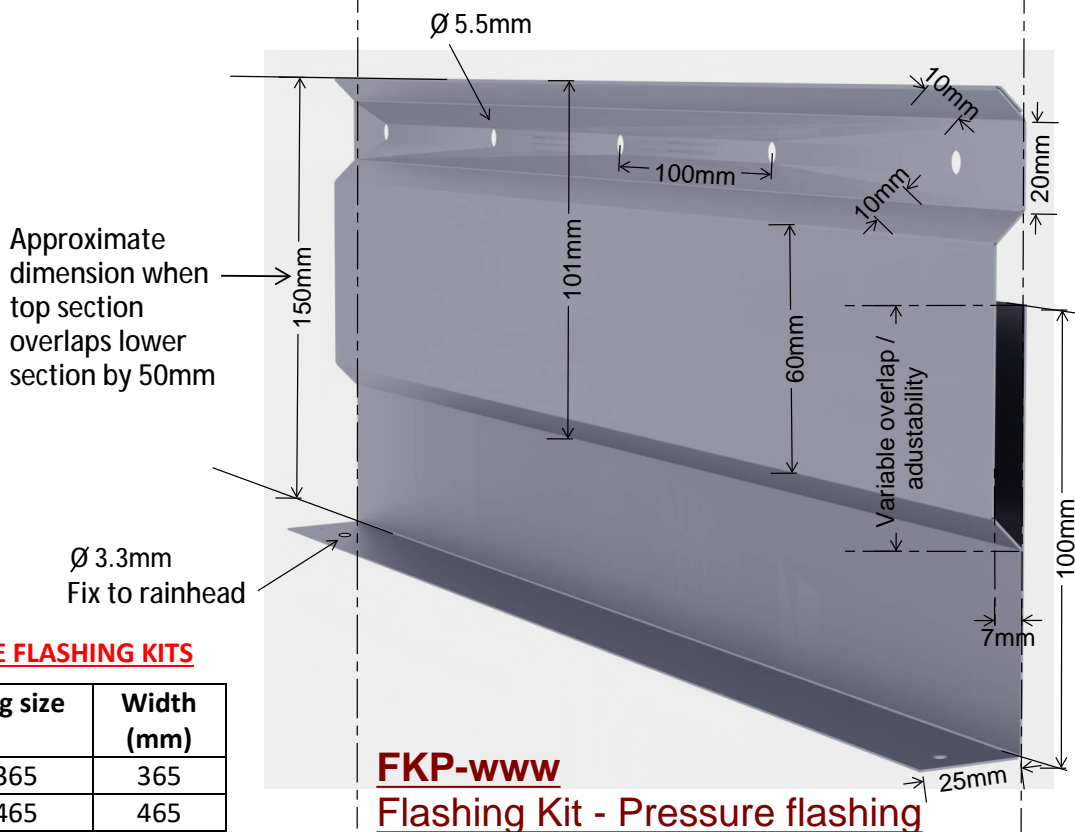

PRESSURE FLASHING KITS

Flashing size	Width (mm)
FKP-365	365
FKP-465	465
FKP-665	665

FKP-ww
Flashing Kit - Pressure flashing



Appendix E

Risk Management (Design) & Maintenance of Box Gutter Systems



Risk Management (Design) & Maintenance of Box Gutter Systems

E1 *Failure of box gutter installations*

Box gutter systems can and do fail - far more often than they should - and have consequently developed a 'bad reputation'. As a result, Architects and Building Designers often fear box gutters, but this fear is unfounded for a well-designed and constructed box gutter system incorporating adequate and compliant overflow devices.

Failure predominately occurs due to one or more of the following factors:

- Inadequate / non-existent design and documentation, particularly concerning overflow provision and box gutter depths.
- Non-compliant / poor construction and installation
- Inadequate maintenance of box gutters

E2 *Current quality of design and documentation for roof drainage in Australia*

The level of design and documentation of box gutter systems in Australia is currently generally very poor. There are multiple reasons for this, including the following:

- Incorrect design on Architectural plans
- A lack of understanding, including by Building Certifiers, of the basic principles of roof drainage design
- Non-compliant / poor construction and installation
- AS/NZS 3500.3 is not an easy code to design to, and lacks flexibility in design, providing only three types of overflow devices
- Building Surveyors / Certifiers often do not require certification for roof drainage designs, particularly for residential and multi-unit residential type buildings. However, with introduction of new NCC Governing Provision A2.2(4) on 1 July 2021, Building Certifiers are increasingly requiring that the Performance Solution process be adhered to when the roof drainage is clearly not DtS (Deemed-to-Satisfy)

E3 ***The Dam Buster Solution to Roof Drainage problems***

Dam Buster seeks to remedy many of the above problems by:

- Providing a simple design / selection process, based on the calculated design flow rate only
- Providing a rainhead which is fully compliant, aesthetically pleasing, has substantial overflow capacity and is also easy to install. Importantly the rainhead also has a novel box gutter receiver, allowing a good seal to be readily achieved between the box gutter and the rainhead. This is important because this junction is a very common point of water ingress into a building.
- Providing a range of innovative overflow devices which provide much greater flexibility for design, specifically:
 - the Dam Buster Side Outlet and Rainhead or Sump combination,
 - the Dam Buster Sump, Continuous Sump and Back-to-Back Sump
 - the Dam Buster Elbow
- Adoption of a minimum depth of 150mm for the penetration for the box gutter in a parapet wall, where a straight box gutter discharges to a rainhead (even though the depth of the box gutter may be closer to 100mm in some cases). Note that the outlet box gutter for the Dam Buster Side Outlets is always a least 200mm deep (and hence the penetration in the parapet wall is a least 200mm deep).

When a box gutter system is designed and installed to comply with the relevant standards and Dam Buster's documentation, the risk of failure is significantly minimized, provided the property owner carries out normal and regular maintenance (refer E6).

E4 ***Design considerations to mitigate against the risk of failure***

The following issues should be considered by designers of box gutter systems in order to minimize the risk of failure:

- A box gutter discharging directly to a Dam Buster Rainhead is the preferred method of discharging water from a box gutter as it places all of the overflow device outside of the building.

Note: The 3500.3 standard Rainhead is only as safe as the Dam Buster Rainhead if the box gutter is adequately sealed to the rainhead. However, without a box gutter receiver, it is much more difficult to get a good seal (and, very commonly, the seal is inadequate). Consequently the 3500.3 Rainhead is considered to be a less safe option than the Dam Buster Rainhead when the box gutter has not been adequately sealed to the rainhead. It is also very rare to see a rainhead installed in accordance with 3500.3, and typically installed rainheads also have inadequate overflow capacity and sizing.
- The next preferred box gutter overflow devices are:
 - The Dam Buster Side Outlet and Rainhead combination
 - The 3500.3 Sump and Side Outlet (when correctly designed and installed)
- The more complicated devices are:
 - The Dam Buster Sump / Continuous Sump / Back-to-Back Sump
 - The Dam Buster Side Outlet and Sump combination
 - The 3500.3 Sump / High-Capacity Overflow device

- Note
 - The above devices have similar safety when installed 'internally' i.e. not immediately adjacent to a parapet wall
 - However, when the Dam Buster Sump is installed immediately adjacent to a parapet wall, the 90mm diameter Full Blockage Overflow Indicator should be installed whenever possible to increase the safety of this device, particularly if there are nearby trees which are expected to deposit organic material in the gutters (refer also to the note below). A common example of the usage of this device in lieu of a rainhead is where a rainhead cannot be installed due to a window or door opening being present below a box gutter which is perpendicular to the parapet wall.
- The usage of 200mm wide box gutters should be avoided wherever possible. Dam Buster recommends all new box gutters be 300mm minimum wide, and notes 3500.3, section 3.7.3, Note 3 states:

"The minimum width of box gutters used for commercial construction is 300mm. Box gutters 200mm wide may be used for domestic construction, but they are more prone to blockages. Additional height is recommended where possible"
- When utilizing the Dam Buster Elbow to facilitate a 90 degree change in direction, it is important to consider that in the 200mm size in particular, this will slightly increase the risk of blockage, purely due to the reduced self-cleaning action as alerted to in section 3.7.3 of 3500.3 above. As a result, for roofs with nearby trees or the risk of other wind-blown debris, or any other conditions which may lead to potentially higher risk of box gutter obstruction, the 200mm Dam Buster Elbow is not recommended (300mm min is recommended).
 - Note that the Dam Buster Elbow has been hydraulically designed and tested to ensure the energy loss at the bend (change of direction) is less than the energy created by means of the Step built into the Elbow. This design ensures that backwatering in the 'Upper' box gutter cannot occur. Additionally, this device has more freeboard built into the design than other devices.

E5 **Summary – Risk Management**

In summary, there are various matters to consider when designing roof drainage, and also various strategies to minimize the risk of failure. A well-considered design in accordance with the relevant standards and also using the Dam Buster Roof Drainage System, carried out during the design process (i.e. as part of the Building Permit documentation) will, if correctly installed, ensure compliance and also minimize the risk of any potential failure of a box gutter system.

E6 **Cleaning / maintenance of box gutter systems**

AS/NZS 3500.3-2021, section M.5, states:

'Sizing of stormwater drainage installations assumes the responsible owner or manager arranges regular inspection and cleaning to remove any obstructions that could reduce the installation's hydraulic capacity or design lifetime, or both.

Obstructions that could cause partial or complete reduction in the hydraulic capacity are windborne plastics, drink cans, builder's refuse, balls, bird nests, items deposited by birds, dead birds, leaves, moss, mortar, silt or similar obstructions.

Guards on gutters and gutter outlets and screens on outlets from on-site stormwater detention (OSD) facilities are installed to prevent reduction in hydraulic capacity due to obstructions. Installation of such guards and screens does not eliminate the need for regular inspection and cleaning. Guards used with rainwater goods might collect debris during high intensity storms, in spite of regular inspection and cleaning, and for this reason it might be better not to install such guards, particularly on box gutter sumps'

Whilst ideally all owners would carry out regular inspection and maintenance, this often does not happen, and consequently it is incumbent on the roof drainage designer to minimize the risk of failure in the first instance through good, compliant design.

Good design, where possible, should include the provision of safe access to allow regular inspection and maintenance to be carried out to the roof stormwater drainage system.

E7 **Sump Deflector Covers**

Note 3 of Clause 3.7.7.1 *Hydraulic capacity, AS/NZS 3500.3-2021* states '*Where water flowing directly into the overflow is a problem, a deflector or cap may be installed to divert the water*'.

Dam Buster's Sump Deflector Cover 'SDC' has been designed to prevent nuisance flows and may be installed in conjunction with all types of Dam Buster Sumps. It is noted, however, the installation of the SDC may increase maintenance (cleaning) requirements, and consequently the SDC is noted as 'Optional'. The roof drainage designer, in consultation with the architect / building designer and client, must decide whether it is appropriate to install the SDC. It is recommended the SDC is generally only installed where 'nuisance flows' will be problematic, such as at building entries.

Note that where the SDCs are installed to Back-to-Back Sumps, the installation method is such that the 'secondary overflow' between the rear walls of the sumps is maintained (i.e. the SDCs have a dual function). Refer to the standard detail for Back-to-Back Sumps.

E8 **Limitations**

At all times, normal good practices and "common sense" must be observed when designing, specifying and installing roof drainage systems. It is also very important to consider that whilst the Dam Buster Roof Drainage System is thoroughly engineered and tested, if instructions and relevant codes are not followed, failure may still occur.

As Dam Buster products contain significant Intellectual Property which is not made publicly available for commercial reasons, it is therefore also strongly recommended that designs only be carried out by those who are experienced with roof drainage design and with Dam Buster products and documentation including Performance Solutions.

It is important to remember that Deemed-to-Satisfy Solutions represent the minimum acceptable solutions to satisfy the relevant Performance Requirements. Whilst a properly prepared Performance Solution does not have to comply with the DtS provisions, the level of safety of a Performance Solution should logically not be of a lesser quality / safety than that for a Deemed-to-Satisfy Solution to the same situation. It therefore follows that Performance Solutions should never be used as a means by which to justify a non-compliant DtS Solution, nor any outcome which provides a lower level of quality / safety than a DtS solution.



Appendix F

Box gutter design charts



Design chart for box gutters discharging to Dam Buster free flow devices

IMPORTANT - DO NOT USE for the following Dam Buster DtS devices:

SSO – Sump and Side Overflow

HCO – High-Capacity Overflow

Minimum UPSTREAM box gutter depth (mm) for **1 in 200*** slope

* 1:200 slope equates to **5mm per m increasing depth** over the length of the gutter

Design flow rate L/s	Example Box gutter width (mm)								
	200	250	300	350	400	450	500	550	600
3.0	107	101	96	93	90	88	86	84	83
3.5	113	105	100	96	93	91	89	87	85
4.0	118	110	104	100	96	94	91	89	88
4.5	122	114	107	103	99	96	94	92	90
5.0	127	118	111	106	102	99	96	94	92
5.5	131	121	114	109	105	101	99	96	94
6.0	135	125	118	112	107	104	101	98	96
6.5	140	129	121	115	110	106	103	101	98
7.0	144	132	124	118	113	109	105	103	100
7.5	148	135	127	120	115	111	107	105	102
8.0	151	139	130	123	118	113	110	107	104
8.5	155	142	133	125	120	115	112	108	106
9.0	159	145	135	128	122	118	114	110	107
9.5	162	148	138	131	125	120	116	112	109
10.0	166	151	141	133	127	122	118	114	111
10.5	170	154	144	135	129	124	119	116	113
11.0		157	146	138	131	126	121	118	114
11.5		160	149	140	133	128	123	119	116
12.0		163	151	142	135	130	125	121	118
12.5		166	154	145	137	132	127	123	119
13.0		169	156	147	140	134	129	124	121
13.5			159	149	142	135	130	126	122
14.0			161	151	144	137	132	128	124
14.5			164	154	146	139	134	129	125
15.0			166	156	148	141	135	131	127
15.5			168	158	149	143	137	132	128
16.0				160	151	144	139	134	130

Example

300mm wide box gutter

Flow rate = 6.0 L/s

=> Minimum UPSTREAM depth = 118mm

Recommend rounding up to nearest 5mm => Adopt 120mm UPSTEAM depth

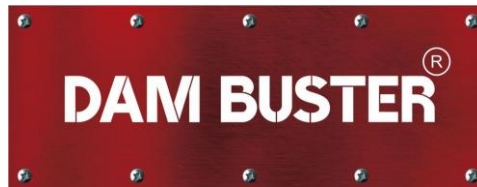

Design chart for box gutters discharging to Dam Buster free flow devices

IMPORTANT - DO NOT USE for the following Dam Buster DtS devices:

SSO – Sump and Side Overflow

HCO – High-Capacity Overflow

Minimum UPSTREAM box gutter depth (mm) for **1 in 150*** slope

* 1:150 equates to **7mm approx. per m** increasing depth over the length of the gutter

Design flow rate L/s	Example Box gutter width (mm)								
	200	250	300	350	400	450	500	550	600
3.0	104	98	94	90	88	86	84	82	81
3.5	109	102	97	94	91	88	87	85	83
4.0	113	106	101	97	94	91	89	87	86
4.5	118	110	104	100	96	94	91	89	88
5.0	122	113	107	103	99	96	94	92	90
5.5	126	117	110	105	102	98	96	94	92
6.0	130	120	113	108	104	101	98	96	94
6.5	134	124	116	111	106	103	100	98	95
7.0	138	127	119	113	109	105	102	99	97
7.5	141	130	122	116	111	107	104	101	99
8.0	145	133	125	118	113	109	106	103	101
8.5	148	136	127	121	116	111	108	105	102
9.0	152	139	130	123	118	113	110	107	104
9.5	155	142	133	125	120	115	112	108	106
10.0	158	145	135	128	122	117	113	110	107
10.5	162	148	138	130	124	119	115	112	109
11.0		150	140	132	126	121	117	113	110
11.5		153	142	134	128	123	119	115	112
12.0		156	145	136	130	125	120	117	113
12.5		158	147	139	132	126	122	118	115
13.0		161	149	141	134	128	124	120	116
13.5			152	143	136	130	125	121	118
14.0			154	145	138	132	127	123	119
14.5			156	147	139	133	128	124	121
15.0			158	149	141	135	130	126	122
15.5			161	151	143	137	132	127	123
16.0				153	145	138	133	129	125

Example

300mm wide box gutter

Flow rate = 6.0 L/s

=> Minimum UPSTREAM depth = 113mm

Recommend rounding up to nearest 5mm => Adopt 115mm UPSTREAM depth

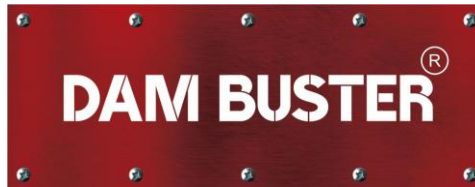

Design chart for box gutters discharging to Dam Buster free flow devices

IMPORTANT - DO NOT USE for the following Dam Buster DtS devices:

SSO – Sump and Side Overflow

HCO – High-Capacity Overflow

Minimum UPSTREAM box gutter depth (mm) for **1 in 100*** slope

* 1:100 slope equates to **10mm per m** increasing depth over the length of the gutter

Design flow rate L/s	Example Box gutter width (mm)								
	200	250	300	350	400	450	500	550	600
3.0	102	96	92	89	86	84	83	81	80
3.5	106	100	95	92	89	87	85	83	82
4.0	110	103	98	95	92	89	87	86	84
4.5	115	107	102	98	94	92	90	88	86
5.0	119	110	105	100	97	94	92	90	88
5.5	122	114	108	103	99	96	94	92	90
6.0	126	117	110	106	102	98	96	94	92
6.5	130	120	113	108	104	101	98	96	94
7.0	133	123	116	110	106	103	100	97	95
7.5	137	126	119	113	108	105	102	99	97
8.0	140	129	121	115	110	107	103	101	98
8.5	143	132	124	117	113	109	105	102	100
9.0	147	135	126	120	115	110	107	104	102
9.5	150	137	129	122	117	112	109	106	103
10.0	153	140	131	124	119	114	110	107	105
10.5	156	143	133	126	120	116	112	109	106
11.0		145	136	128	122	118	114	110	108
11.5		148	138	130	124	119	115	112	109
12.0		150	140	132	126	121	117	113	110
12.5		153	142	134	128	123	119	115	112
13.0		155	144	136	130	124	120	116	113
13.5			147	138	131	126	122	118	115
14.0			149	140	133	128	123	119	116
14.5			151	142	135	129	125	121	117
15.0			153	144	137	131	126	122	119
15.5			155	146	138	132	128	123	120
16.0				148	140	134	129	125	121

Example

300mm wide box gutter

Flow rate = 6.0 L/s

=> Adopt 110mm UPSTREAM depth



Design chart for box gutters discharging to Dam Buster free flow devices

IMPORTANT - DO NOT USE for the following Dam Buster DtS devices:

SSO – Sump and Side Overflow

HCO – High-Capacity Overflow

Minimum UPSTREAM box gutter depth (mm) for **1 in 40*** slope

* 1:40 slope equates to **25mm per m** increasing depth over length of the gutter

Design flow rate L/s	Example Box gutter width (mm)								
	200	250	300	350	400	450	500	550	600
3.0	93	88	85	83	81	79	78	77	76
3.5	96	91	88	85	83	81	80	78	77
4.0	100	94	90	87	85	83	82	80	79
4.5	103	97	93	90	87	85	83	82	81
5.0	106	100	95	92	89	87	85	83	82
5.5	109	102	97	94	91	89	87	85	84
6.0	112	105	100	96	93	90	88	86	85
6.5	115	107	102	98	95	92	90	88	86
7.0	118	110	104	100	96	94	91	89	88
7.5	120	112	106	102	98	95	93	91	89
8.0	123	114	108	103	100	97	94	92	90
8.5	126	117	110	105	101	98	96	93	92
9.0	128	119	112	107	103	100	97	95	93
9.5	131	121	114	109	105	101	98	96	94
10.0	133	123	116	110	106	103	100	97	95
10.5	136	125	118	112	108	104	101	98	96
11.0		127	119	114	109	105	102	100	97
11.5		129	121	115	111	107	104	101	99
12.0		131	123	117	112	108	105	102	100
12.5		133	125	118	113	109	106	103	101
13.0		135	126	120	115	111	107	104	102
13.5			128	122	116	112	108	105	103
14.0			130	123	118	113	110	107	104
14.5			131	125	119	115	111	108	105
15.0			133	126	120	116	112	109	106
15.5			135	127	122	117	113	110	107
16.0				129	123	118	114	111	108

Example

300mm wide box gutter

Flow rate = 6.0 L/s

=> Adopt 100mm UPSTREAM depth



Appendix G

Aerial downpipe design chart



Design chart for aerial downpipes

Slope	Pipe diameter			
	90mm	100mm	150mm	225mm
1 in 200	4.14	5.49	16.2	47.5
1 in 190	4.26	5.65	16.6	48.9
1 in 180	4.39	5.82	17.1	50.3
1 in 170	4.53	6.00	17.7	51.9
1 in 160	4.68	6.21	18.3	53.7
1 in 150	4.85	6.43	18.9	55.6
1 in 140	5.04	6.68	19.6	57.7
1 in 130	5.25	6.96	20.5	60.1
1 in 120	5.49	7.27	21.4	62.7
1 in 110	5.76	7.63	22.4	65.7
1 in 100	6.07	8.04	23.6	69.2
1 in 90	6.43	8.52	25.0	73.3
1 in 80	6.86	9.09	26.7	78.0
1 in 70	7.38	9.77	28.7	83.9
1 in 60	8.03	10.6	31.2	91.1
1 in 50	8.87	11.7	34.4	100.4

Maximum flow rates* (L/s)

* Based on a standard Colebrook-White calculator

Note

The table assumes there are no additional bends in the aerial downpipe other than the bend below the sump. Where there are additional bends, which will result in energy losses, advice should be obtained from a hydraulic engineer.